

SPLIT-TYPE AIR CONDITIONERS

OUTDOOR UNIT PARTS CATALOG



No. OBB865

Models

MUZ-FT25VGHZ - E1, ET1, SC1

MUZ-FT35VGHZ - E1, ET1, SC1

MUZ-FT50VGHZ - E1, ET1, SC1

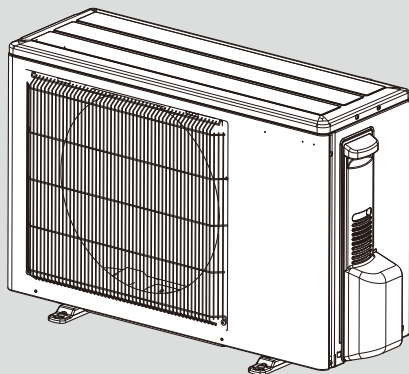

MUZ-FT25VGHZ

CONTENTS

1. SERVICE PARTS LIST2

SERVICE MANUAL (OBH865)

1

SERVICE PARTS LIST

MUZ-FT25VGHZ

1-1. OUTDOOR UNIT STRUCTURAL PARTS AND FUNCTIONAL PARTS

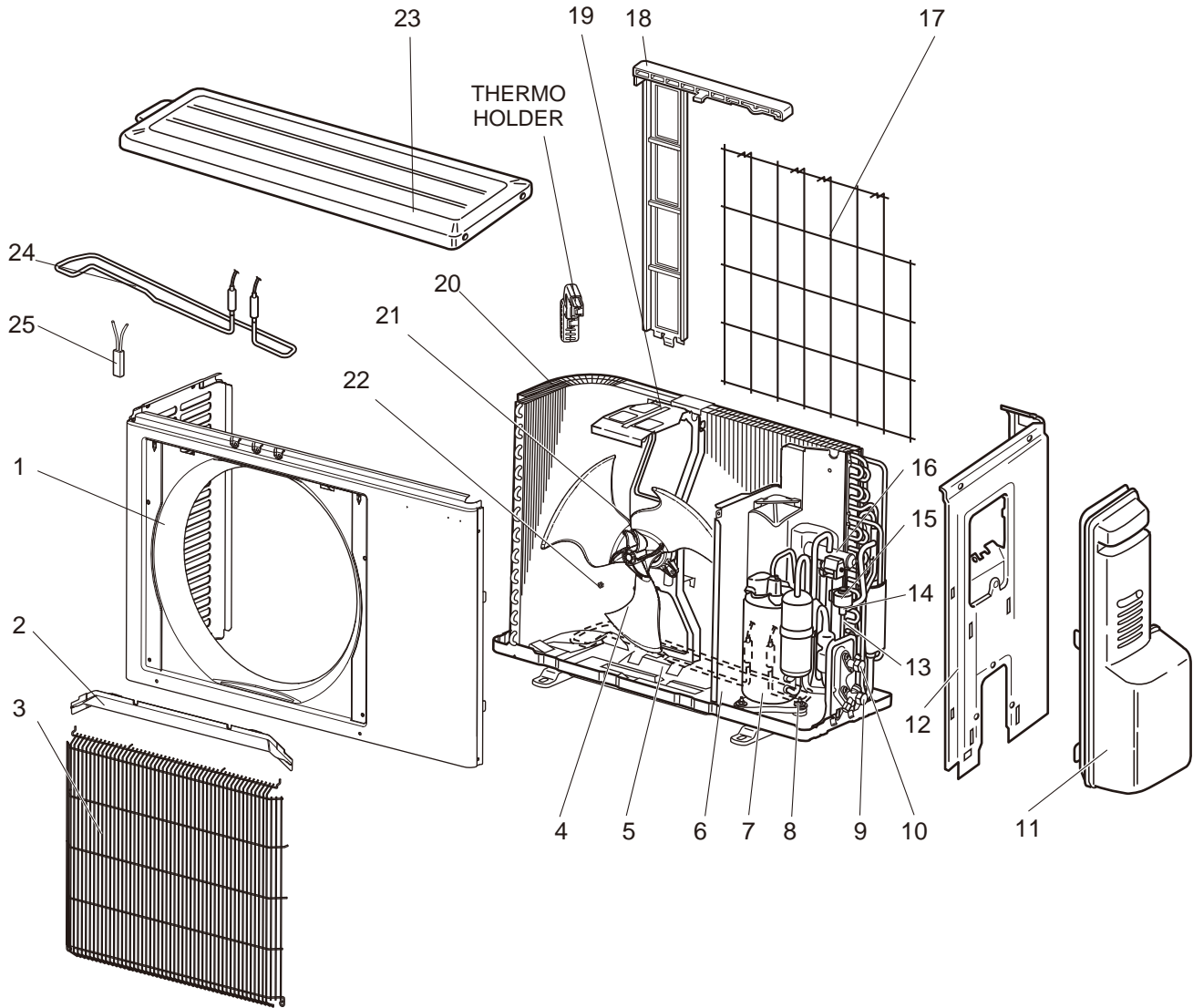

1-2. OUTDOOR UNIT ELECTRICAL PARTS

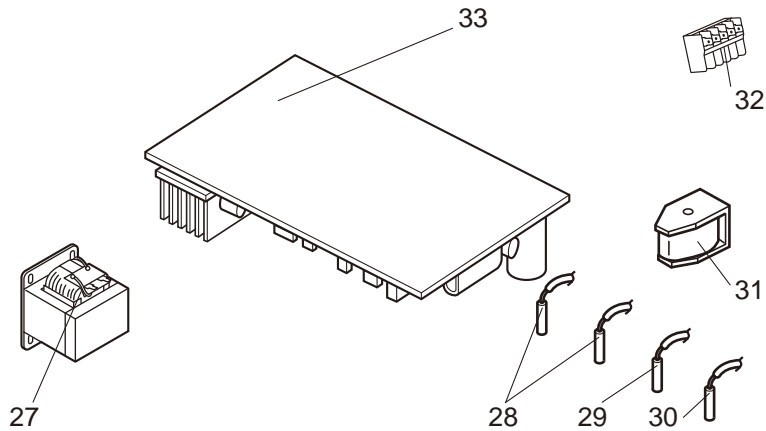

1-1. OUTDOOR UNIT STRUCTURAL PARTS AND FUNCTIONAL PARTS

1. The part quantity below indicates the required number of pieces per unit.
2. The circled No. indicates that the part is not shown in the figure.

No.	Part No.	Part Name	Symbol in Wiring Diagram	MUZ-FT25VGHZ- ^[E1]	MUZ-FT25VGHZ- ^[E1]	MUZ-FT25VGHZ- ^[SCT]	Remarks
1	E22 J63 232	CABINET		1	1	1	
2	E22 J63 531	ICE GUARD		1	1	1	
3	E22 Y84 521	GRILLE (OUT)		1	1	1	
4	E22 95B 501	PROPELLER FAN		1	1	1	
5	E22 Y96 290	BASE		1	1	1	
6	E22 G14 293	SEPARATOR		1	1	1	
7	E22 R83 900	COMPRESSOR	MC	1	1	1	SVB130FBBMT
8	E22 C34 506	COMPRESSOR RUBBER SET		3	3	3	3 RUBBERS/SET
9	E22 T66 661	STOP VALVE (GAS)		1	1	1	ø9.52
10	E22 43J 662	STOP VALVE (LIQUID)		1	1	1	ø6.35
11	E22 L59 245	SERVICE PANEL		1	1	1	
12	E22 G15 233	BACK PANEL (OUT)		1	1	1	
13	E22 41M 645	EXPANSION VALVE ASSEMBLY		1	1	1	Includes LEV body and capillary tube
14	E22 Y84 640	EXPANSION VALVE		1	1	1	
15	E22 Y84 493	EXPANSION VALVE COIL	LEV	1	1	1	
16	E22 39G 961	4-WAY VALVE		1	1	1	
17	E22 930 525	CONDENSER WIRE NET		1	1	1	
18	E22 930 523	CONDENSER NET		1	1	1	
19	E22 14F 515	MOTOR SUPPORT		1	1	1	
20	E22 Y84 630	OUTDOOR HEAT EXCHANGER		1	1	1	
21	E22 97B 301	OUTDOOR FAN MOTOR	MF	1	1	1	RC0J50-□□
22	E27 L05 508	PROPELLER FAN NUT		1	1	1	
23	E22 L85 297	TOP PANEL		1	1	1	
24	E22 Y96 526	DEFROST HEATER	H	1	1	1	Includes lead assembly
25	E22 D65 381	HEATER PROTECTOR	26H	1	1	1	
(26)	E22 41M 936	CAPILLARY TUBE		1	1	1	ø3.0×ø1.8×240

1-2. OUTDOOR UNIT ELECTRICAL PARTS

No.	Part No.	Part Name	Symbol in Wiring Diagram	MUZ-FT25VGHZ- ^[E1]	MUZ-FT25VGHZ- ^[E1]	MUZ-FT25VGHZ- ^[SCT]	Remarks
27	E22 20A 337	REACTOR	L61	1	1	1	
28	E22 R81 306	THERMISTOR SET	RT61, RT62	1	1	1	DEFROST, DISCHARGE
29	E22 D65 308	AMBIENT TEMPERATURE THERMISTOR	RT65	1	1	1	
30	E22 P72 307	OUTDOOR HEAT EXCHANGER TEMPERATURE THERMISTOR	RT68	1	1	1	
31	E22 39G 490	R.V. COIL	21S4	1	1	1	
32	E22 10L 374	TERMINAL BLOCK	TB1	1	1	1	5P
33	E22 41M 451	INVERTER P.C. BOARD		1	1	1	Includes heat sink and RT64

MUZ-FT35VGHZ MUZ-FT50VGHZ
1-3. OUTDOOR UNIT STRUCTURAL PARTS, ELECTRICAL PARTS AND FUNCTIONAL PARTS

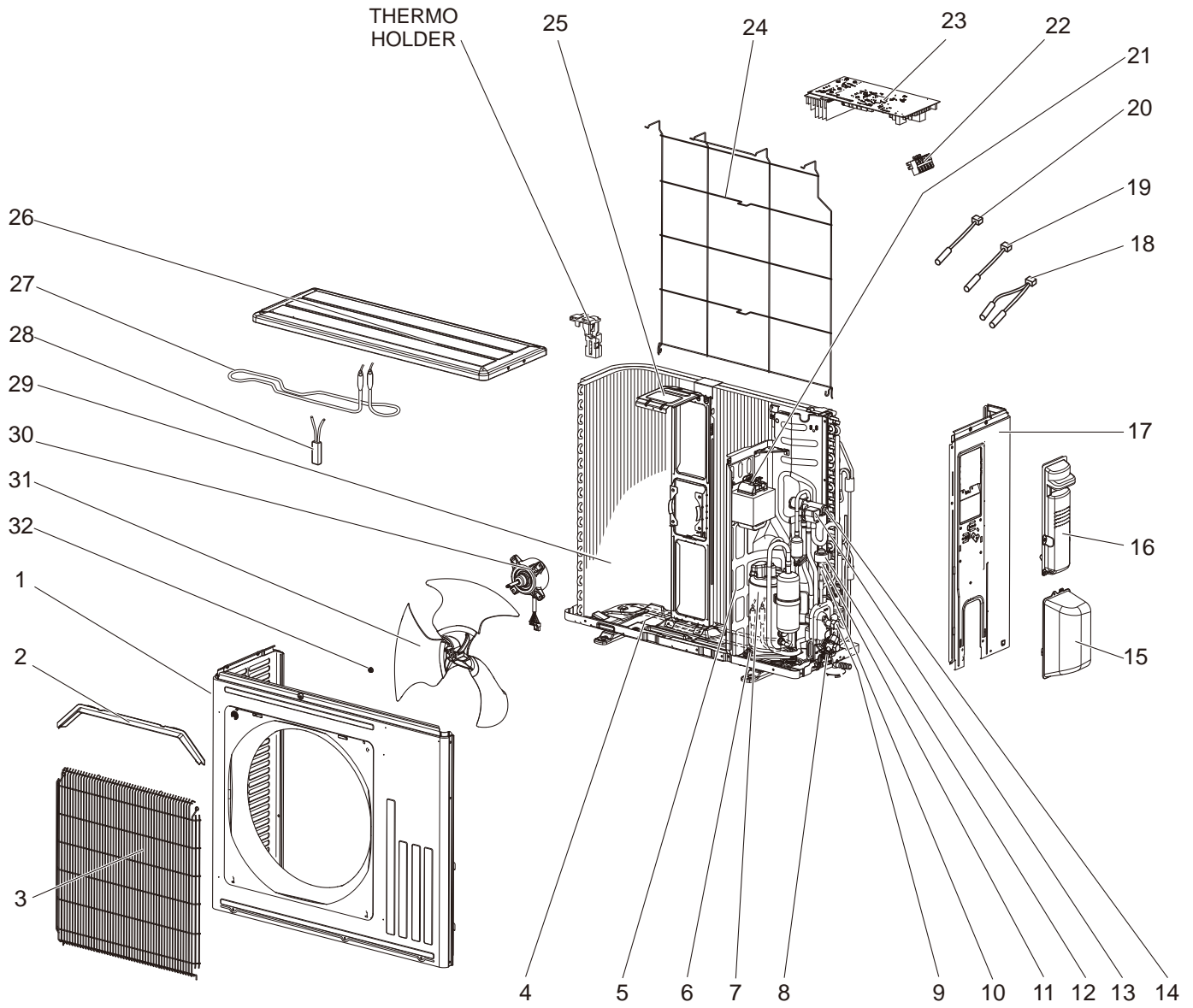

1-3. OUTDOOR UNIT STRUCTURAL PARTS, ELECTRICAL PARTS AND FUNCTIONAL PARTS

1. The part quantity below indicates the required number of pieces per unit.
2. The circled No. indicates that the part is not shown in the figure.

No.	Part No.	Part Name	Symbol in Wiring Diagram	MUZ-FT35VGHZ-	MUZ-FT35VGHZ-	MUZ-FT35VGHZ-	MUZ-FT50VGHZ-	MUZ-FT50VGHZ-	MUZ-FT50VGHZ-	Remarks
				ET	ET1	SC1	ET	ET1	SC1	
1	E22 Y86 232	CABINET		1	1	1	1	1	1	
2	E22 Y86 531	ICE GUARD		1	1	1	1	1	1	
3	E22 Y86 521	GRILLE (OUT)		1	1	1	1	1	1	
4	E22 Y96 290	BASE		1	1	1	1	1	1	
5	E22 42M 293	SEPARATOR		1	1	1	1	1	1	
6	E22 C34 506	COMPRESSOR RUBBER SET		3	3	3	3	3	3	3 RUBBERS/SET
7	E22 R83 900	COMPRESSOR	MC	1	1	1	1	1	1	SVB130FBBMT
8	E22 Y86 661	STOP VALVE (GAS)		1	1	1	1	1	1	ø9.52
9	E22 Y86 662	STOP VALVE (LIQUID)		1	1	1	1	1	1	ø6.35
10	E22 41G 645	EXPANSION VALVE ASSEMBLY		1	1	1	1	1	1	Includes LEV body and capillary tube
11	E22 Y84 640	EXPANSION VALVE		1	1	1	1	1	1	
12	E22 Y84 493	EXPANSION VALVE COIL	LEV	1	1	1	1	1	1	
13	E22 42M 490	R.V. COIL	21S4	1	1	1	1	1	1	
14	E22 42M 961	4-WAY VALVE		1	1	1	1	1	1	
15	E22 Y86 650	VALVE COVER		1	1	1	1	1	1	
16	E22 Y86 245	SERVICE PANEL		1	1	1	1	1	1	
17	E22 Y86 233	BACK PANEL (OUT)		1	1	1	1	1	1	
18	E22 Y86 306	THERMISTOR SET	RT61, RT62	1	1	1	1	1	1	DEFROST, DISCHARGE
19	E22 C34 307	OUTDOOR HEAT EXCHANGER TEMPERATURE THERMISTOR	RT68	1	1	1	1	1	1	
20	E22 J52 309	AMBIENT TEMPERATURE THERMISTOR	RT65	1	1	1	1	1	1	
21	E22 N94 337	REACTOR	L61	1	1	1	1	1	1	
22	E22 13L 374	TERMINAL BLOCK	TB1	1	1	1	1	1	1	5 P
23	E22 42M 451	INVERTER P.C. BOARD		1	1	1				Includes heat sink and RT64
23	E22 43M 451	INVERTER P.C. BOARD					1	1	1	Includes heat sink and RT64
24	E22 Y86 525	CONDENSER WIRE NET		1	1	1	1	1	1	
25	E22 Y86 515	MOTOR SUPPORT		1	1	1	1	1	1	
26	E22 Y86 297	TOP PANEL		1	1	1	1	1	1	
27	E22 42M 526	DEFROST HEATER	H	1	1	1				
27	E22 03B 526	DEFROST HEATER	H				1	1	1	
28	E22 03B 381	HEATER PROTECTOR	26H	1	1	1	1	1	1	
29	E22 Y86 630	OUTDOOR HEAT EXCHANGER		1	1	1	1	1	1	
30	E22 Y86 301	OUTDOOR FAN MOTOR	MF	1	1	1	1	1	1	RC0J50-□□
31	E22 Y86 501	PROPELLER FAN		1	1	1	1	1	1	
32	E27 L05 508	PROPELLER FAN NUT		1	1	1	1	1	1	
③3	E22 P72 936	CAPILLARY TUBE		1	1	1	1	1	1	ø4.0 x ø2.4 x 240

mitsubishi electric corporation

HEAD OFFICE: TOKYO BUILDING, 2-7-3, MARUNOUCHI, CHIYODA-KU, TOKYO 100-8310, JAPAN

© Copyright 2020 MITSUBISHI ELECTRIC CORPORATION

Published: Jun. 2020. No. OBB865

Made in Japan

Specifications are subject to change without notice.