

INDOOR UNIT

No. OBH902

REVISED EDITION-A

SERVICE MANUAL

Models

MSZ-RW25VG - **E1**, **SC1**

MSZ-RW35VG - **E1**, **SC1**

MSZ-RW50VG - **E1**, **SC1**

**Outdoor unit service manual
MUZ-RW•VG Series (OBH903)**

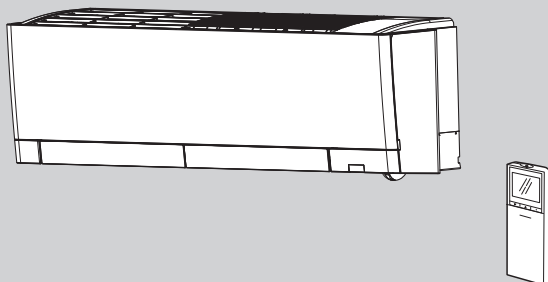

CONTENTS

1. TECHNICAL CHANGES	3
2. PART NAMES AND FUNCTIONS	4
3. SPECIFICATION	5
4. NOISE CRITERIA CURVE	6
5. OUTLINES AND DIMENSIONS	7
6. WIRING DIAGRAM	8
7. REFRIGERANT SYSTEM DIAGRAM	9
8. SERVICE FUNCTIONS	10
9. MICROPROCESSOR CONTROL	18
10. TROUBLESHOOTING	30
11. DISASSEMBLY INSTRUCTIONS	46

PARTS CATALOG (OBB902)

Use the specified refrigerant only

Never use any refrigerant other than that specified.

Doing so may cause a burst, an explosion, or fire when the unit is being used, serviced, or disposed of.

Correct refrigerant is specified in the manuals and on the spec labels provided with our products.

We will not be held responsible for mechanical failure, system malfunction, unit breakdown or accidents caused by failure to follow the instructions.

<Preparation before the repair service>

- Prepare the proper tools.
- Prepare the proper protectors.
- Provide adequate ventilation.
- After stopping the operation of the air conditioner, turn off the power-supply breaker and pull the power plug.
- Discharge the capacitor before the work involving the electric parts.

<Precautions during the repair service>

- Do not perform the work involving the electric parts with wet hands.
- Do not pour water into the electric parts.
- Do not touch the refrigerant.
- Do not touch the hot or cold areas in the refrigeration cycle.
- When the repair or the inspection of the circuit needs to be done without turning off the power, exercise great caution not to touch the live parts.

WARNING

- When the refrigeration circuit has a leak, do not execute pump down with the compressor.
- When pumping down the refrigerant, stop the compressor before disconnecting the refrigerant pipes. The compressor may burst if air etc. get into it.
- When opening or closing the valve below freezing temperatures, refrigerant may spurt out from the gap between the valve stem and the valve body, resulting in injuries.

Revision A:

- Test point of 12 V DC has been corrected. (Refer to 10-6.© "Check of indoor P.C. board and indoor fan motor" and 10-7. "TEST POINT DIAGRAM AND VOLTAGE".)

1

TECHNICAL CHANGES

The following models are compatible with the outdoor units with low standby power control.

Connecting the following models to the MUZ-RW·VGHZ series outdoor units enables the low standby power control.

The following models may be connected to the MUZ-RW·VGHZ series after once connected to the MXZ series and operated, for example because of relocation. In that case, the MUZ-RW·VGHZ series outdoor units will not operate without taking a step.

Follow the procedure "Deleting the memorized abnormal condition" described in 10-2.1.

MSZ-RW25VG - E1, SC1

MSZ-RW35VG - E1, SC1

MSZ-RW50VG - E1, SC1

1. New model

2

PART NAMES AND FUNCTIONS

MSZ-RW25VG
MSZ-RW35VG
MSZ-RW50VG

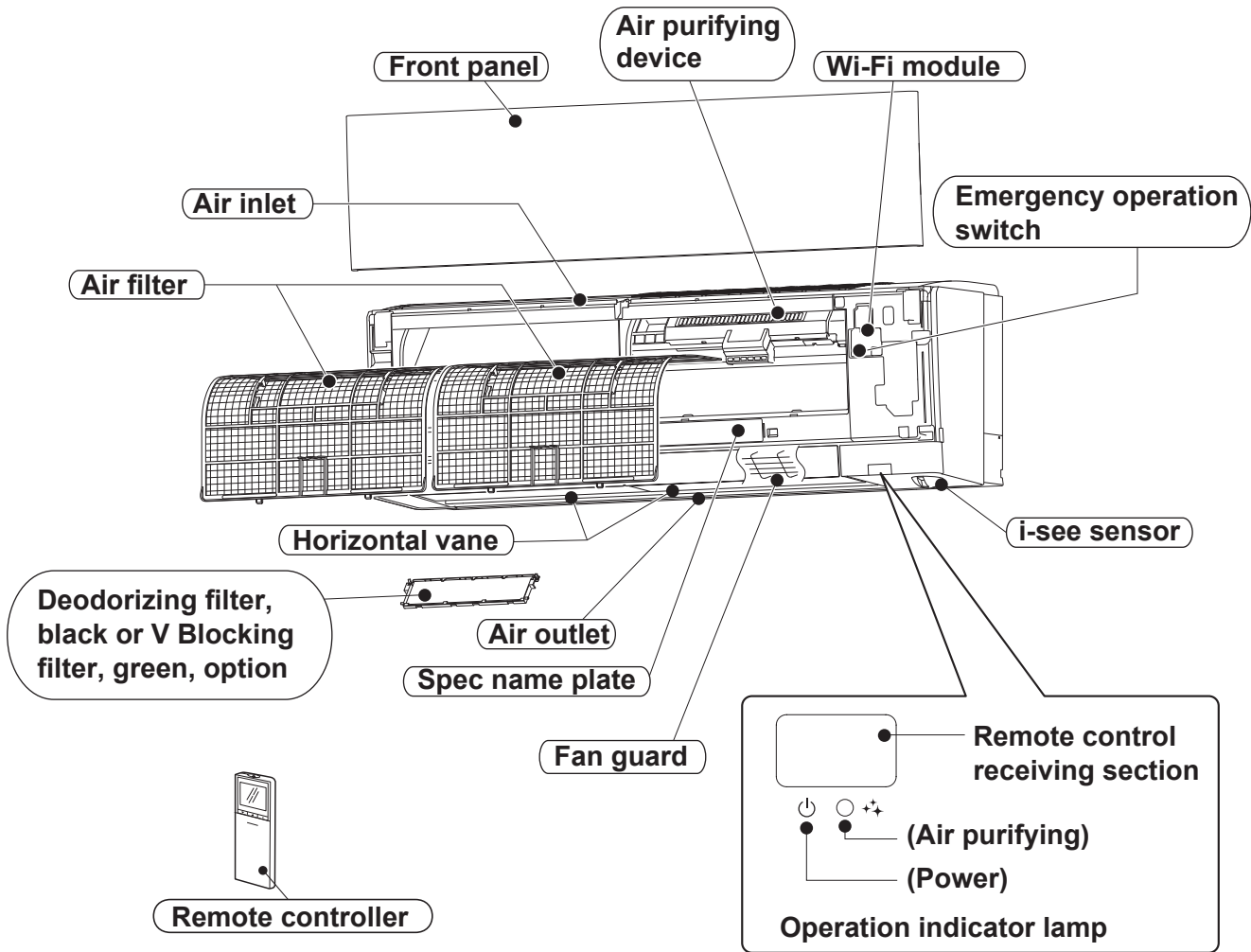

ACCESSORIES

Model	All models
(1) Installation plate	1
(2) Installation plate fixing screw 4 × 25 mm	5
(3) Wireless remote controller	1
(4) Felt tape (For left or left-rear piping)	1
(5) Battery (AAA) for remote controller	2
(6) Air cleaning filter (Deodorizing filter, black)	1
(7) Air purifying device	1

3

SPECIFICATION

Indoor model				MSZ-RW25VG	MSZ-RW35VG	MSZ-RW50VG	
Power supply				Single phase 230 V, 50 Hz			
Electrical data	Power input *1	Cooling	W	19	21	29	
		Heating		21	22	41	
	Running current *1	Cooling	A	0.20	0.21	0.28	
		Heating		0.21	0.22	0.37	
Fan motor	Model			RC0J40-SA			
	Current *1	Cooling	A	0.20	0.21	0.28	
Heating			0.21	0.22	0.37		
Dimensions W × H × D			mm			998 × 305 × 247	
Weight			kg			14.5	
Special remarks	Air direction			5			
	Airflow	Cooling	Super High	m³/h	822	846	972
			High		690	786	
			Med.		540	666	
			Low		390	414	570
			Silent		306	468	
		Heating	Super High	m³/h	846	870	1092
			High		702	882	
			Med.		570	750	
			Low		468	642	
			Silent		306	468	
	Sound level	Cooling	Super High	dB(A)	42	43	45
			High		36	39	
			Med.		29	34	
			Low		23	24	30
			Silent		19	26	
		Heating	Super High	dB(A)	41	42	46
			High		36	41	
			Med.		30	37	
			Low		25	32	
			Silent		19	25	
	Fan speed	Cooling	Super High	rpm	900	920	1,020
			High		790	870	
			Med.		660	770	
			Low		530	550	690
			Silent		450	600	
		Heating	Super High	rpm	920	940	1,120
			High		800	950	
Med.			690		840		
Low			600		750		
Silent			450		600		
Fan speed regulator			5				
Remote controller model	- [E]			SH21A			
	- [SC]			SH21B			

NOTE: Test conditions are based on ISO 5151.

Cooling: Indoor Dry-bulb temperature 27°C Wet-bulb temperature 19°C

Outdoor Dry-bulb temperature 35°C

Heating: Indoor Dry-bulb temperature 20°C

Outdoor Dry-bulb temperature 7°C Wet-bulb temperature 6°C

*1 Measured under rated operating frequency.

Specifications and rating conditions of main electric parts

Fuse	(F11)	T3.15AL250 V
Horizontal vane motor	(MV1)	12 V DC
Vertical vane motor	(MV2)	12 V DC
i-see SENSOR MOTOR	(MT)	12 V DC
Varistor	(NR11)	470 V
Terminal block	(TB)	3P

MSZ-RW25VG

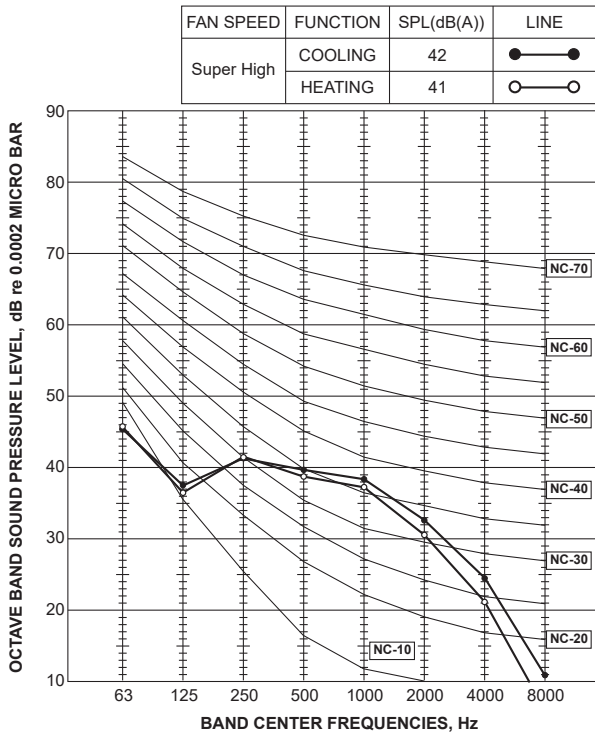

MSZ-RW35VG

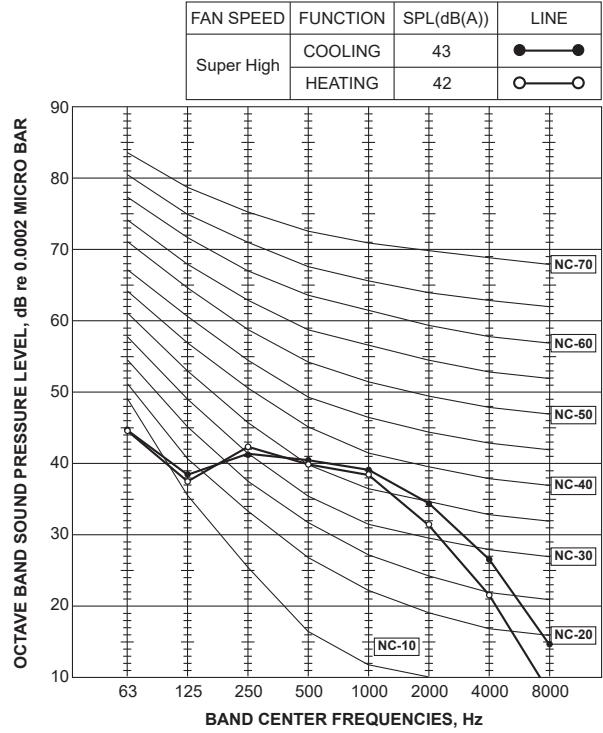

MSZ-RW50VG

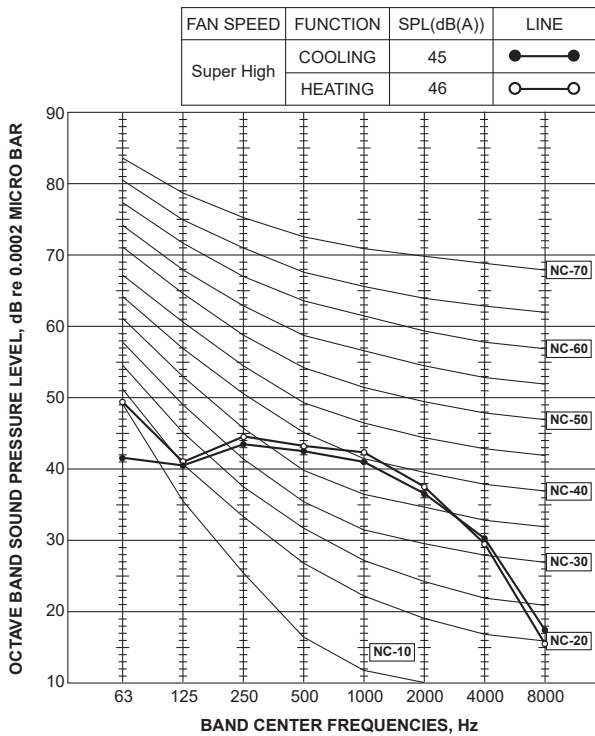

Test conditions

- Cooling: Dry-bulb temperature 27 °C
Wet-bulb temperature 19 °C
- Heating: Dry-bulb temperature 20 °C

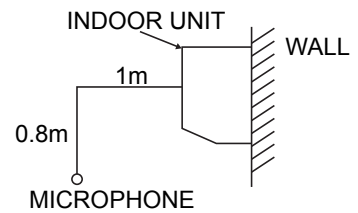

5

OUTLINES AND DIMENSIONS

**MSZ-RW25VG
MSZ-RW35VG
MSZ-RW50VG**

Unit: mm

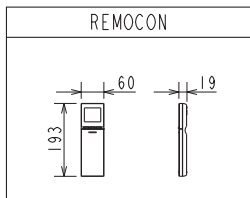
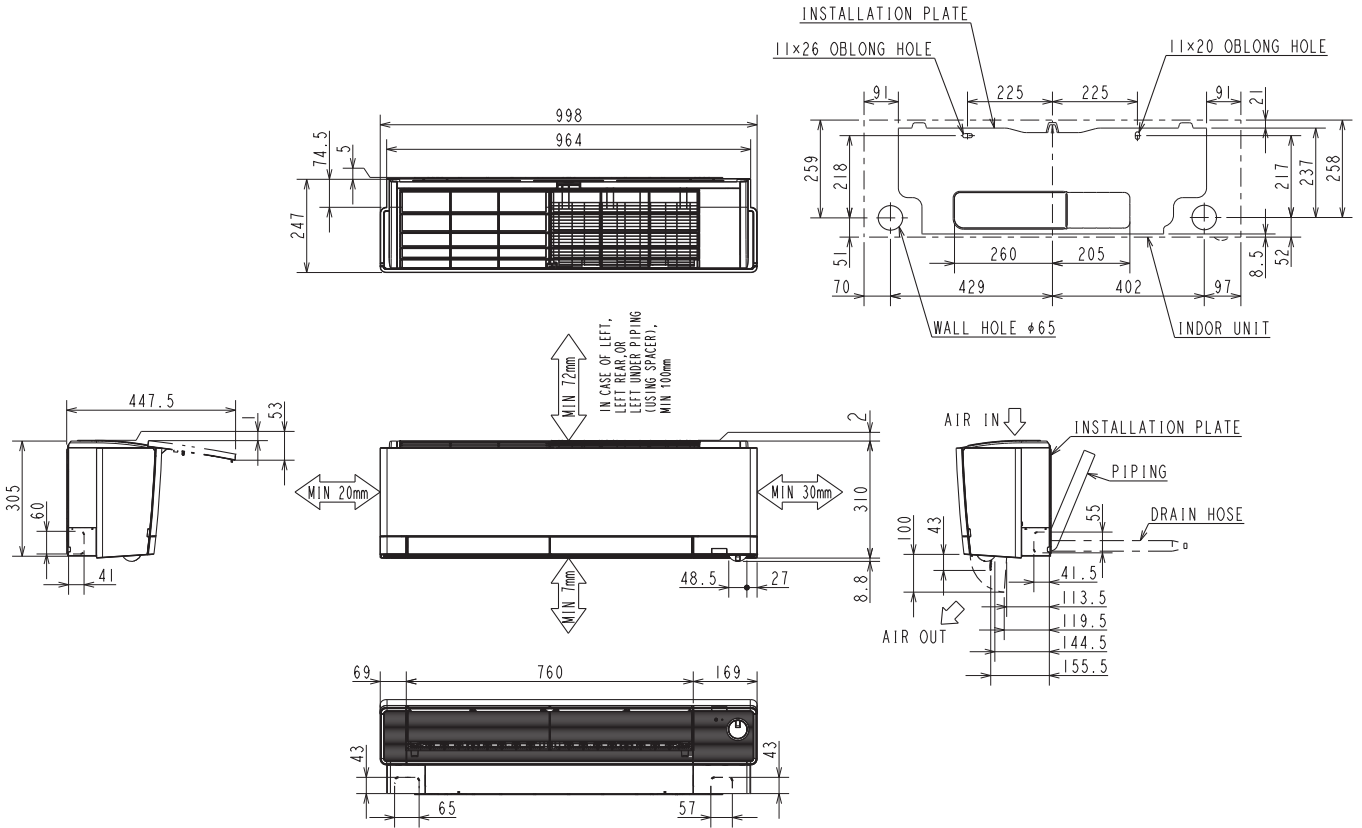

MSZ-RW25/35/50VG-E1			MSZ-RW25/35/50VG-SC1		
PIPING	INSULATION	ø37 O.D	PIPING	INSULATION	ø37 O.D
	LIQUID LINE	ø6.35 - 0.5m (FLARED CONNECTION ø6.35)		LIQUID LINE	ø6.35 - 0.64m (FLARED CONNECTION ø6.35)
	GAS LINE	ø9.52 - 0.45m (FLARED CONNECTION ø9.52)		GAS LINE	ø9.52 - 0.59m (FLARED CONNECTION ø12.7)
DRAIN HOSE	INSULATION ø29 CONNECTED PART ø16 O.D		DRAIN HOSE	INSULATION ø29 CONNECTED PART ø16 O.D	

MSZ-RW25VG
MSZ-RW35VG
MSZ-RW50VG

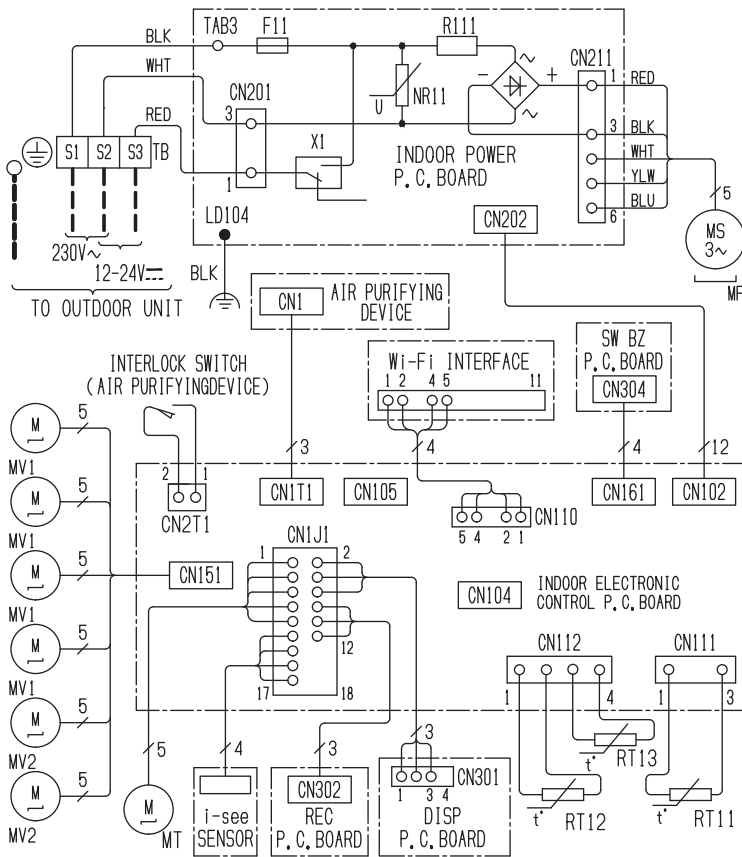

SYMBOL	NAME
F11	FUSE (T3, 15AL250V)
MF	FAN MOTOR
MV1	VANE MOTOR (HORIZONTAL)
MV2	VANE MOTOR (VERTICAL)
MT	i-see SENSOR MOTOR
NR11	VARISTOR
R111	RESISTOR
RT11	ROOM TEMP. THERMISTOR
RT12	COIL TEMP. THERMISTOR (MAIN)
RT13	COIL TEMP. THERMISTOR (SUB)
TB	TERMINAL BLOCK
X1	RELAY

NOTES: 1. About the outdoor side electronic wiring refer to the outdoor unit electronic wiring diagram for servicing.
2. Use copper supply wires.
3. Symbols indicate, : Terminal block : Connector

7

REFRIGERANT SYSTEM DIAGRAM

MSZ-RW25VG
MSZ-RW35VG

Unit: mm

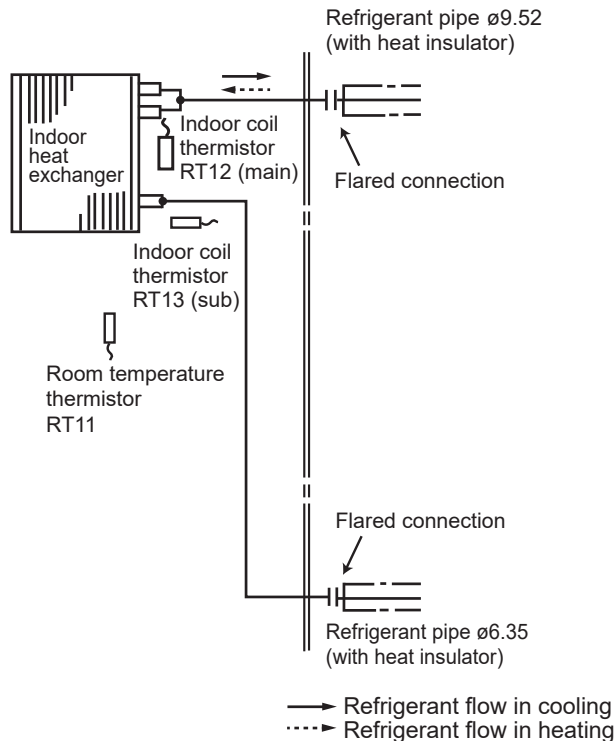

MSZ-RW50VG

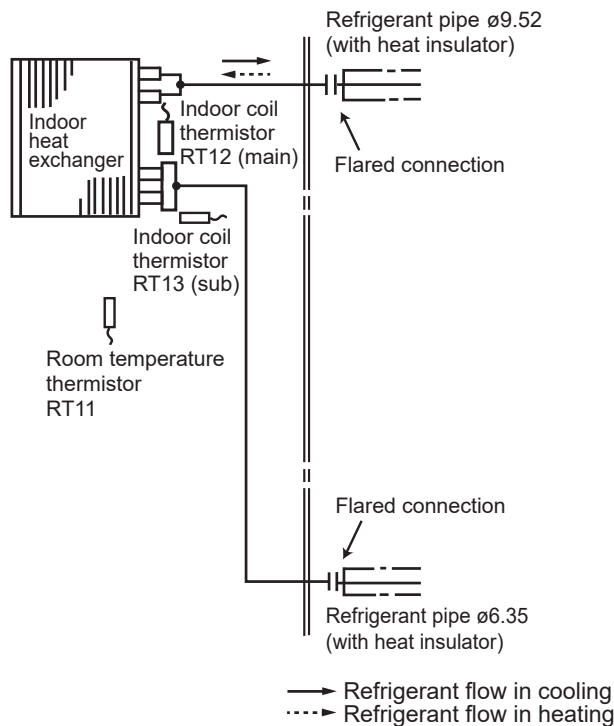

**MSZ-RW25VG
MSZ-RW35VG
MSZ-RW50VG**

8-1. TIMER SHORT MODE

For service, the following set time can be shortened by bridging the timer short mode point on the electronic control P.C. board.

(Refer to 10-7.)

- The set time for the ON/OFF timer can be reduced to 1 second for each minute.
- After the breaker is turned on, the time for starting the compressor, which normally takes 3 minutes, can be reduced to 1 minute. Restarting the compressor, which takes 3 minutes, cannot be reduced.





8-2. HOW TO SET REMOTE CONTROLLER EXCLUSIVELY FOR A PARTICULAR INDOOR UNIT

A maximum of 4 indoor units with wireless remote controllers can be used in a room.

To operate the indoor units individually with each remote controller, assign a number to each remote controller according to the number of the indoor unit.

This setting can be set only when all the following conditions are met:

- The remote controller is powered OFF.
- Weekly timer is not set.
- Weekly timer is not being edited.

- (1) Hold down  button on the remote controller for 2 seconds to enter the pairing mode.
- (2) Press  button again and assign a number to each remote controller.
Each press of  button advances the number in the following order: 1 → 2 → 3 → 4.
- (3) Press  button to complete the pairing setting.

After you turn the breaker ON, the remote controller that first sends a signal to an indoor unit will be regarded as the remote controller for the indoor unit.

Once they are set, the indoor unit will only receive the signal from the assigned remote controller afterwards.

8-3. SETTING THE INSTALLATION POSITION

Be sure to set the remote controller according to the installed position of the indoor unit.

Installation position:

Left: Distance to objects (wall, cabinet, etc.) is less than 50 cm to the left



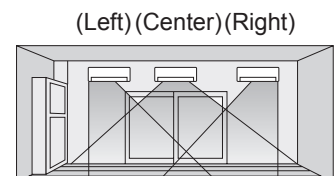

Center: Distance to objects (wall, cabinet, etc.) is more than 50 cm to the left and right



Right: Distance to objects (wall, cabinet, etc.) is less than 50 cm to the right



The installation position can be set only when all the following conditions are met:

- The remote controller is powered OFF.
- Weekly timer is not set.
- Weekly timer is not being edited.

- (1) Hold down  button on the remote controller for 2 seconds to enter the position setting mode.
- (2) Select the target installation position by pressing  button. (Each press of the  button displays the positions in order: center → right → left.)
- (3) Press  button to complete the position setting.

Installation position	Left	Center	Right
Remote controller display			

8-4. AUTO RESTART FUNCTION

When the indoor unit is controlled with the remote controller, the operation mode, the set temperature, and the fan speed are memorized by the indoor electronic control P.C. board. "AUTO RESTART FUNCTION" automatically starts operation in the same mode just before the shutoff of the main power.

Operation

- ① If the main power has been cut, the operation settings remain.
- ② After the power is restored, the unit restarts automatically according to the memory.
(However, it takes at least 3 minutes for the compressor to start running.)

How to disable "AUTO RESTART FUNCTION"

- ① Turn off the main power for the unit.
- ② Cut the jumper wire to JR77 on the indoor electronic control P.C. board. (Refer to 10-7.)

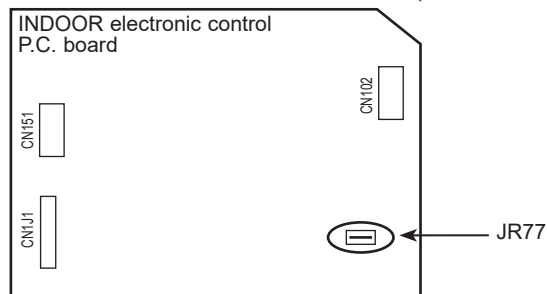

NOTE:

- The operation settings are memorized when 10 seconds have passed after the indoor unit was operated with the remote controller.
- If main power is turned OFF or a power failure occurs while AUTO START/STOP timer is active, the timer setting is cancelled.
- If the unit has been turned OFF with the remote controller before power failure, the auto restart function does not work as the power button of the remote controller is OFF.
- To prevent the breaker from tripping OFF due to the rush of starting current, systematize other home appliance not to turn ON at the same time.
- When some air conditioners are connected to the same supply system, if they are operated before power failure, the starting current of all the compressors may flow simultaneously at restart. Therefore, the special counter-measures are required to prevent the main voltage-drop or the rush of the starting current by adding to the system that allows the units to start one by one.

8-5. Wi-Fi MODULE SETTING UP

This Wi-Fi module communicates the status information and controls the commands from the MELCloud by connecting to an indoor unit.

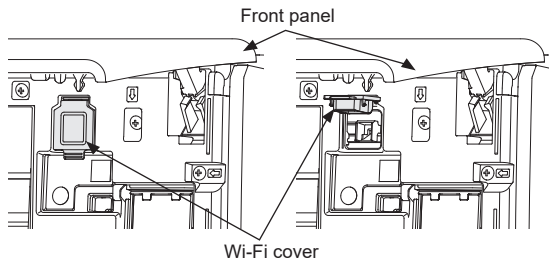

1. Wi-Fi module introduction

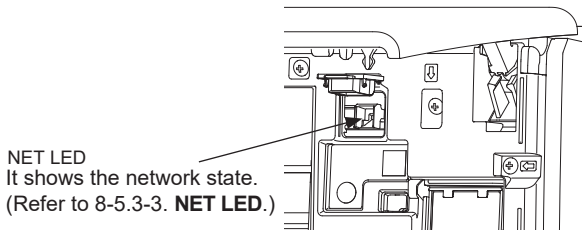

2. Setting up

Set up a connection between the Wi-Fi module and the router.

NOTE:

Setup is possible only after operating the air conditioner using the wireless remote controller.

For MELCloud User Manual, please go to the website below.
www.melcloud.com/Support
 After accessing the address above, select "United Kingdom" to view support details.

3. Selecting a mode

The Wi-Fi module has to be paired with the router in order for communication between the indoor unit and MELCloud to begin. There are 2 methods of pairing the Wi-Fi module with the router:

- WPS-PUSH mode
- Access Point mode

The mode to be set depends on whether your router has the WPS button.

Use the pairing mode most suitable for your system.

Follow the instructions below to set the pairing mode with Remote controller.

Set up the Wi-Fi module and the router again when the router has been replaced.

To reset connection and set up the Wi-Fi module and the router again

- (1) Hold down the Temperature \ominus for 5 seconds.
- (2) Select "_ 2" by pressing Temperature \oplus and \ominus .
- (3) Point the remote controller toward the indoor unit and press the \odot OFF/ON .
- (4) The indoor unit beeps 3 times when resetting is complete.

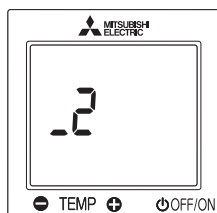

3-1. Setting up in WPS-PUSH mode

To enter the mode

- (1) Hold down the Temperature \oplus for 5 seconds.
- (2) Select "_ 2" by pressing Temperature \oplus and \ominus as shown on the right.
- (3) Point the remote controller toward the indoor unit and press the \odot OFF/ON .

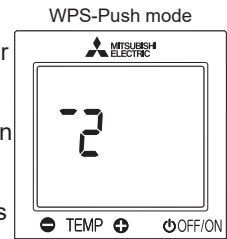

3-1.1. Connect the router to the air conditioner.

Make sure that the LED (Air purifying lamp of the indoor unit) indication is as shown below.

Push WPS button of the router within 2 minutes after the mode selection has completed.

The WPS-PUSH mode will return to initial state if WPS button is not pressed for 2 minutes.

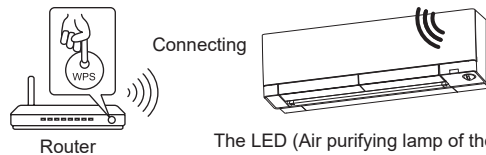

The LED (Air purifying lamp of the indoor unit) lights up for 3 seconds then blinks twice. A beep sounds as the LED (Air purifying lamp of the indoor unit) blinks. This series of actions is repeated.

3-1-2. LED (Air purifying lamp of the indoor unit) will be as shown below when connection between the router and Wi-Fi module is completed and connection to MELCloud starts.

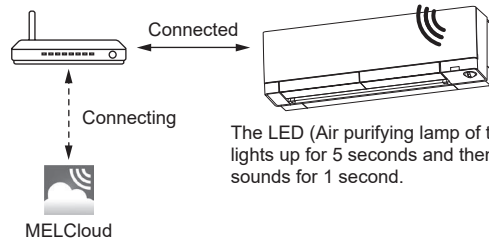

The LED (Air purifying lamp of the indoor unit) lights up for 5 seconds and then a beep sounds for 1 second.

NOTE:

If the indication LED (Air purifying lamp of the indoor unit) does not change or blinks 5 times, connection fails. Please reset connection and setup the Wi-Fi module and the router again.

Main causes that WPS failed are as follows.

Communication distance (from the Wi-Fi module to router), router settings (encryption, authentication, limit of connections, etc.)

3-2. Setting up in Access Point mode

Complete the setting up in the Access Point mode within 10 minutes.

To enter the mode

- (1) Hold down the Temperature \oplus for 5 seconds.
- (2) Select "1" by pressing Temperature \oplus and \ominus as shown on the right.
- (3) Point the remote controller toward the indoor unit unit and press the OFF/ON \square .

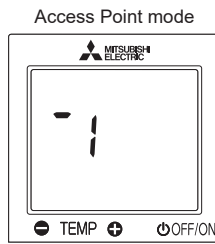

3-2.1. Connect your smartphone to the air conditioner.

Make sure that the LED (Air purifying lamp of the indoor unit) indication is as shown below. On the Wi-Fi Setting Screen on your smartphone, select SSID and enter KEY, which are printed on the information label.

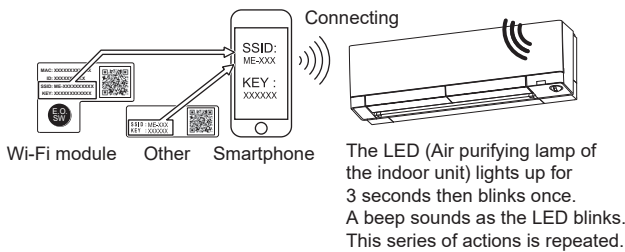

NOTE:

- Check Wi-Fi setting of your smartphone if SSID does not appear on it.
- Enter KEY again if SSID appears on your smartphone, but it cannot connect to the Wi-Fi module.
- The LED (Air purifying lamp of the indoor unit) indication does not change or blinks 5 times if connection fails. In that case, reset connection and set up the Wi-Fi module and the router again.

3-2.2. Access URL (<http://192.168.11.1/network>) by any of the following methods to display the setting screen.

- (1) Scan the matrix barcode below.
- (2) Scan the matrix barcode on the information label.
- (3) Type the URL (<http://192.168.11.1/network>) in the web browser.

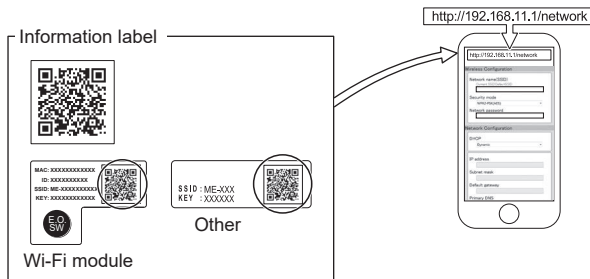

3-2.3. Register the information of the router on the air conditioner.

In the displayed window, select Dynamic in DHCP (*1) and enter the information of router, then tap the Submit button.

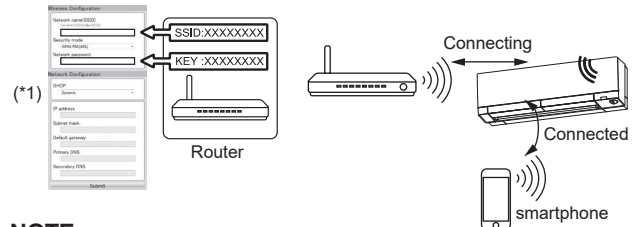

NOTE:

- If you want to use Static, select Static in DHCP (*1) and enter the information of router and network, then tap the Submit button.

3-2.4. LED (Air purifying lamp of the indoor unit) indication will be as shown below when connection between the router and Wi-Fi module is completed and connection to MELCloud starts.

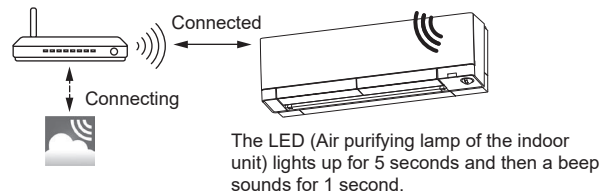

NOTE:

It may take several minutes to show the indication above. The LED (Air purifying lamp of the indoor unit) indication does not change or blinks 5 times if connection fails. In that case, reset connection and set up the Wi-Fi module and the router again.

3-3. NET LED





NET LED blinking indicates that the Wi-Fi module is communicating with the router.

3-4. When it doesn't connect well

Check the following, and pair the Wi-Fi module and the router according to Selecting a mode.

- Make sure that the communication distance is not too far between the Wi-Fi module and the router.
- Make sure that the router uses WPA2-AES encryption.
- Make sure that the number of connected devices to the router does not exceed the limit.
- Make sure that DHCP is enabled, or check IP address setting of the Wi-Fi module.
- Check DNS settings of the router, or check DNS address of the Wi-Fi module.
- Check if the router is connected to Internet.
- Set up the Wi-Fi module after operating the air conditioner using the wirelessremote controller at least once.

If the connection fails even after checking the above, set up the Wi-Fi module and the router again by the following method.

- Hold down the Temperature  for 5 seconds.
- Select “_ 2” by pressing Temperature  and .
- Point the remote controller toward the indoor unit and press the  .
- The indoor unit beeps 3 times when resetting is complete.

[About trademarks]

- WPS is the connection via Wi-Fi Protected Setup.
- “Wi-Fi®”, “Wi-Fi Protected Setup™”, “WPA2™” are trademarks or registered trademarks of the Wi-Fi Alliance.

For Declaration of Conformity and MELCloud User Manual, please go to the website below.
www.melcloud.com/Support
After accessing the address above, select “United Kingdom” to view support details.

The Wi-Fi module uses Open Source Software. To view the Open Source software licence(s), please go to the following website whilst connected to the Wi-Fi module during the Access Point mode.
<http://192.168.11.1/license>

NOTE:

- Ensure that the router supports the WPA2-AES encryption setting before starting the Wi-Fi module setup.
- The End user should read and accept the terms and conditions of the Wi-Fi service before using this Wi-Fi module.
- To complete connection of this Wi-Fi module to the Wi-Fi service, the router may be required.
- This Wi-Fi module will not commence transmission of any operational data from the system until the End user registers and accepts the terms and conditions of the Wi-Fi service.
- This Wi-Fi module should not be installed and connected to any Mitsubishi Electric system which is to provide application critical cooling or heating.
- At the time of relocation or disposal, reset the Wi-Fi module to the factory default.

For the latest information regarding MELCloud from Mitsubishi Electric Corporation, please visit www.melcloud.com.

8-6. CHANGING THE CORRECTION VALUE OF THE ROOM TEMPERATURE (THE INLET TEMPERATURE)

The correction value of the room temperature can be adjusted in the range of 2 to 5 °C with the remote controller.

Normally, the temperature at the room temperature sensor might become higher than that around feet because warm air tends to accumulate around an indoor unit during heating operation.

Thus, if you correct the room temperature to the temperature about 2 °C lower than that detected by the room temperature sensor, the air conditioner capacity during heating operation increases, which suppresses a decrease in the temperature around feet.

The optimal correction values of the room temperature, however, might differ depending on the installation environments such as installation height of the indoor unit or the ceiling height, so adjust the correction value of the room temperature in the range of 2 to 5 °C with the remote controller.

NOTE 1: The room will be warmer if you set the correction value of the room temperature to 5°C.

1. How to change the correction value of the room temperature

(1) Press [① OFF/ON] button on the remote controller to turn the indoor unit off. (Figure 1)

(2) Point the remote controller at the indoor unit.

While you hold down [② MODE] and [③ TEMP \ominus] at the same time, press [④ RESET], and keep holding [② MODE] and [③ TEMP \ominus] to indicate the correction value of the room temperature that was set the last time with the remote controller (Figure 2 shows 2°C at factory setting).

NOTE 2: Point the remote controller at the indoor unit while working in the procedure (3) and (4) like the procedure (2).

(3) Press [③ TEMP \ominus] or [⑤ TEMP \oplus] to change the correction value of the room temperature.

(4) Set the correction value of the room temperature to the desired value, and then press [① OFF/ON] button on the remote controller to turn the indoor unit off. (Figure 1)

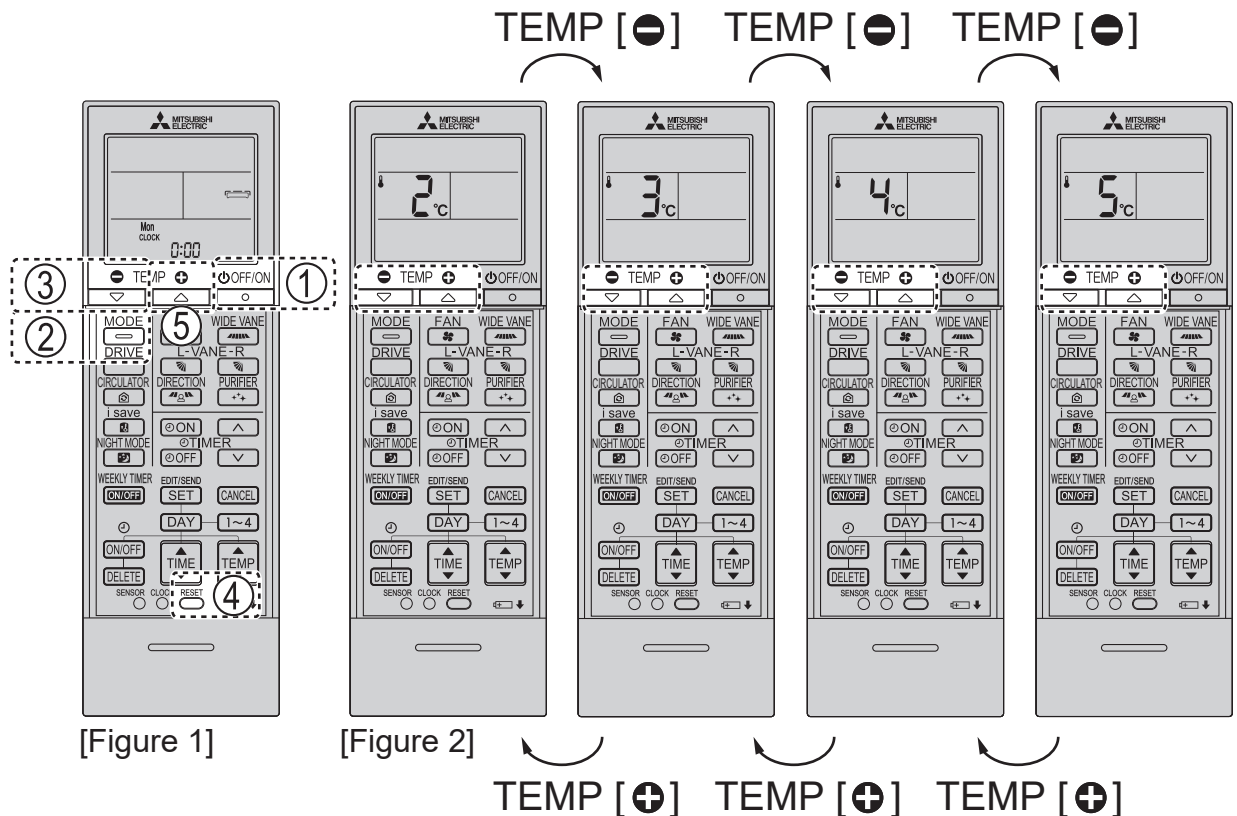

2. Writing the correction value of the room temperature on the wiring diagram

After setting the correction value of the room temperature (the inlet air temperature), follow 11. DISASSEMBLY INSTRUCTIONS to disassemble the indoor unit, and then write the correction value (any of 3, 4, or 5) on the wiring diagram with a ballpoint pen, etc. (e.g. The numerical value is described in the bold square.) (Figure 3)

If the indoor electronic control P.C. board is replaced in servicing, the correction value is reset. The numerical value (any of 3, 4, or 5) described on the wiring diagram will be needed when a service man sets the correction value again after replacing the P.C. board.

NOTE 3: The instruction for setting the correction value again is attached to the indoor electronic control P.C. board of the service part as well.

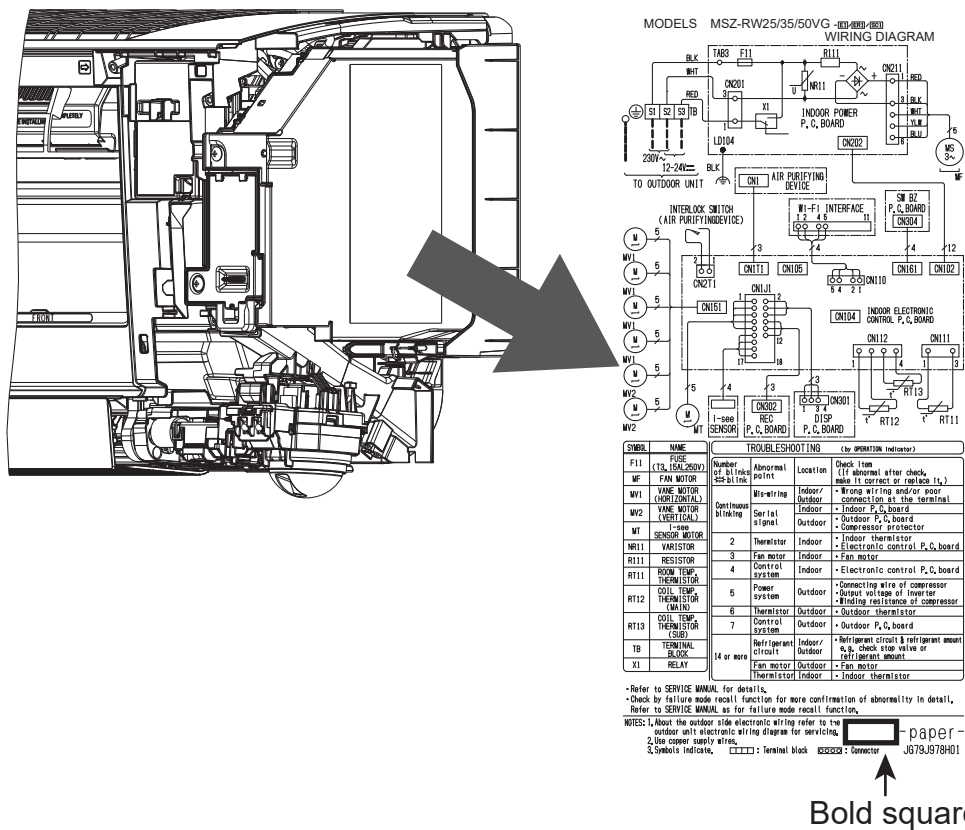

[Figure 3]

If you cut the jumper wire JR24 (Refer to 10-7.), a correction value of the room temperature during heating operation turns to 0°C regardless of the correction commands from the remote controller. (Figure 4)

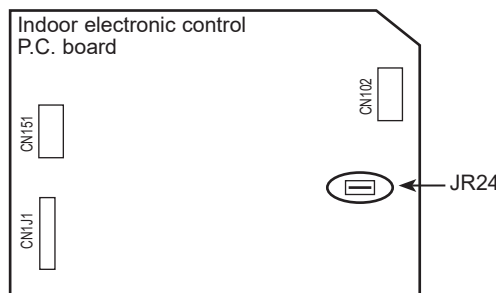

[Figure 4]

8-7. ADJUSTING POSITION GAPS BETWEEN THE LEFT AND RIGHT HORIZONTAL VANES AT UPPER AND LOWER SIDE

When there are position gaps between the left and right horizontal vanes at upper and lower side, follow the procedure below for the service.

1. Prior check

Checks before repairing: check following items (a) to (e) if there are factors causing torsion on the body of the indoor unit installed. Correct the factor if there is a problem.

- Bumps on the installation surface due to a lumber or others.
- Contact of the indoor unit or an installation board with a pillar.
- The wall sleeve, pipes, or drain hose cause the lower part of the indoor unit to be lifted toward you.
- Deformation of a nozzle due to tension of the drain hose or pipes.
- An installation board not installed as described in the installation manual (Refer to the installation manual.)

NOTE 1: If there is no problem in (a) to (e) items, follow the procedure 8-7.2. "How to adjust position gaps of the vanes" below for the service.

2. How to adjust position gaps of the vanes

Prepare the remote controller attached with the product (hereinafter, remote controller). Follow the procedure below to fine-adjust the position gaps (angle) between the left and right vanes at upper and lower side.

NOTE 2: You cannot return the vanes to initial state (angle) by resetting their adjustments amount once adjusting the left and right vanes at upper and lower side.

- Supply the power with the air conditioner.
- Press [① OFF/ON] button on the remote controller to turn the air conditioner and the remote controller off.
- While holding down [② VANE-L] and [③ VANE-R] on remote controller, press [④ RESET], and keep holding [② VANE-L] and [③ VANE-R] until the display changes as shown in Figure 2.
The settings of "cooling" and "horizontal vane angle 1 (horizontal position)" are sent to the indoor unit, and the unit starts the vane adjusting mode.

NOTE 3: Return to (1) if the air conditioner does not operate.

- When the upper and lower vanes are set to the "horizontal vane angle 1 (horizontal position)", press [⑤ [△] [▽]] buttons or [⑥ [^] [v]] buttons on the remote controller to move the positions (angle) of the left vanes need for adjustment.
Pressing [⑤ [△] [▽]] buttons moves the upper left vane and pressing [⑥ [^] [v]] buttons moves the lower left vane. Align the positions of the left vanes with those of the right vanes respectively.
- After the adjustment work is complete, pressing [① OFF/ON] button on the remote controller once allows the remote controller to be turned off as shown in Figure 1; however, the air conditioner does not turn off.
Press [① OFF/ON] button twice more continuously to turn the air conditioner and the remote controller off.
- Adjustment work is complete. Start cooling operation normally to confirm the operation.

NOTE 4 :

- The gap amounts between the left and right vanes at upper and lower side at each vane position (setting position) might differ depending on the installation conditions.

(Please adjust the vanes visually with the indoor unit installed if using the remote controller to correct the position gaps between vanes).

- This method with the remote controller does not support for correcting the position gaps between the vanes with them fully closed and the gaps between the vanes and the body of the indoor unit installed. Check 8-7.1. Prior check whether torsion on the body of the indoor unit installed leads to the position gaps between the vanes with them fully closed or not.
- The adjustments amount using the remote controller neither can be reset nor checked.
- To return the vanes to the initial state, replace the indoor electric control P.C board.
- When the P.C board is replaced after the position gaps have been corrected, readjust the gaps between the left and right vanes at upper and lower side.

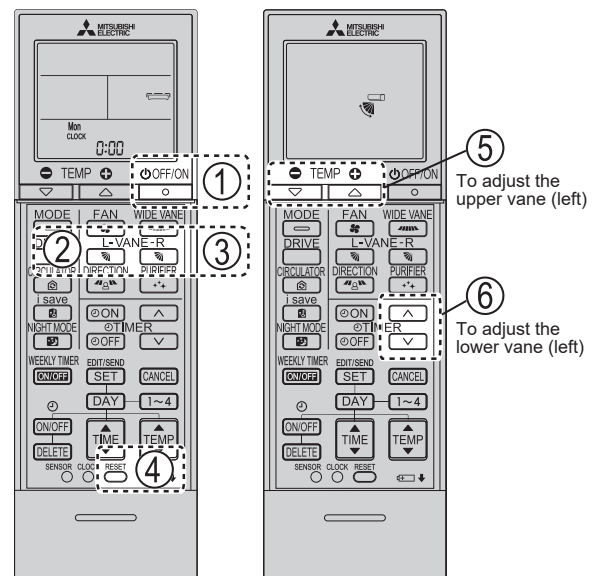

[Figure 1]

Remote controller state:
OFF

[Figure 2]

Remote controller state:
Vane adjusting mode.
(The vane adjusting mode is not canceled even if a certain period has elapsed.)

MSZ-RW25VG - E1
 MSZ-RW35VG - E1
 MSZ-RW50VG - E1

WIRELESS REMOTE CONTROLLER

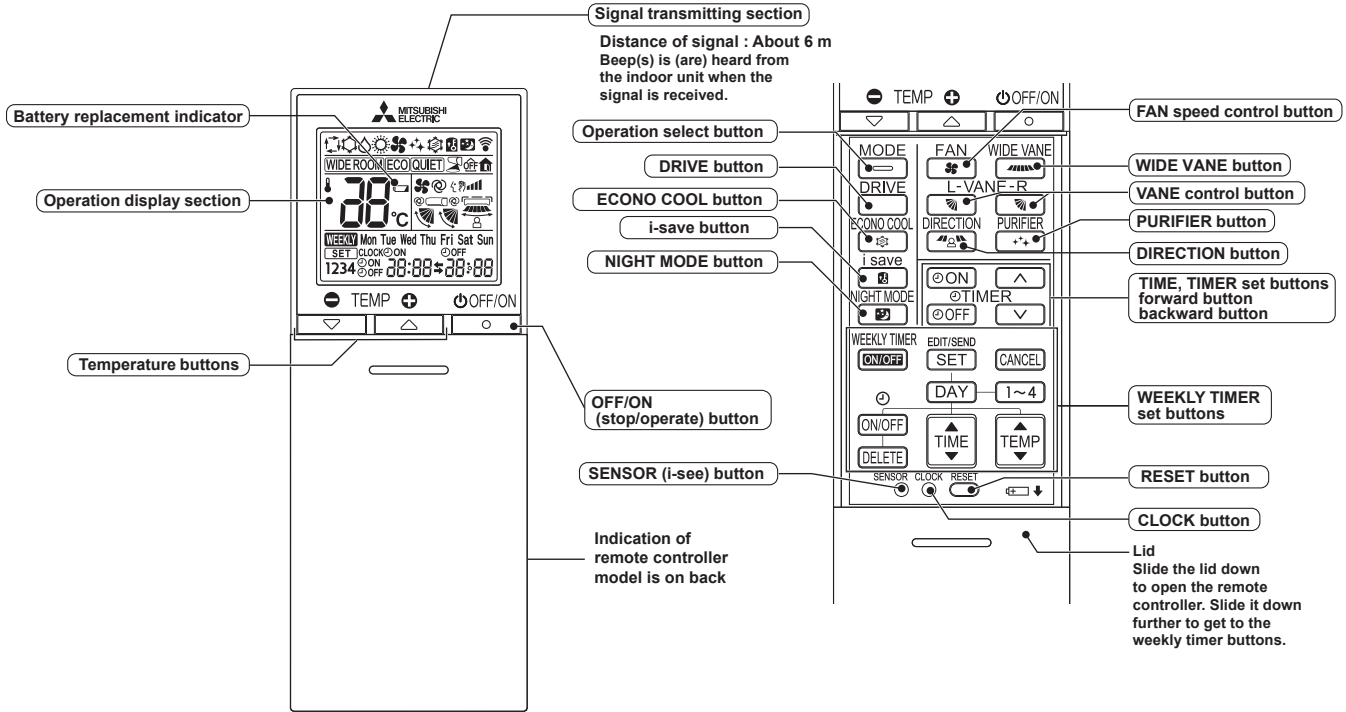

NOTE: Last setting will be stored after the unit is turned OFF with the remote controller. Indoor unit receives the signal of the remote controller with beeps.

INDOOR UNIT DISPLAY SECTION

Operation Indicator lamp

The operation indicator at the right side of the indoor unit indicates the operation state.

•The following indication applies regardless of shape of the indication.

Indication	Operation state	Room temperature
	Standby mode (Only during multi system operation)	—

- Lit
- Blinking
- Not lit

MSZ-RW25VG - SC1
 MSZ-RW35VG - SC1
 MSZ-RW50VG - SC1

WIRELESS REMOTE CONTROLLER

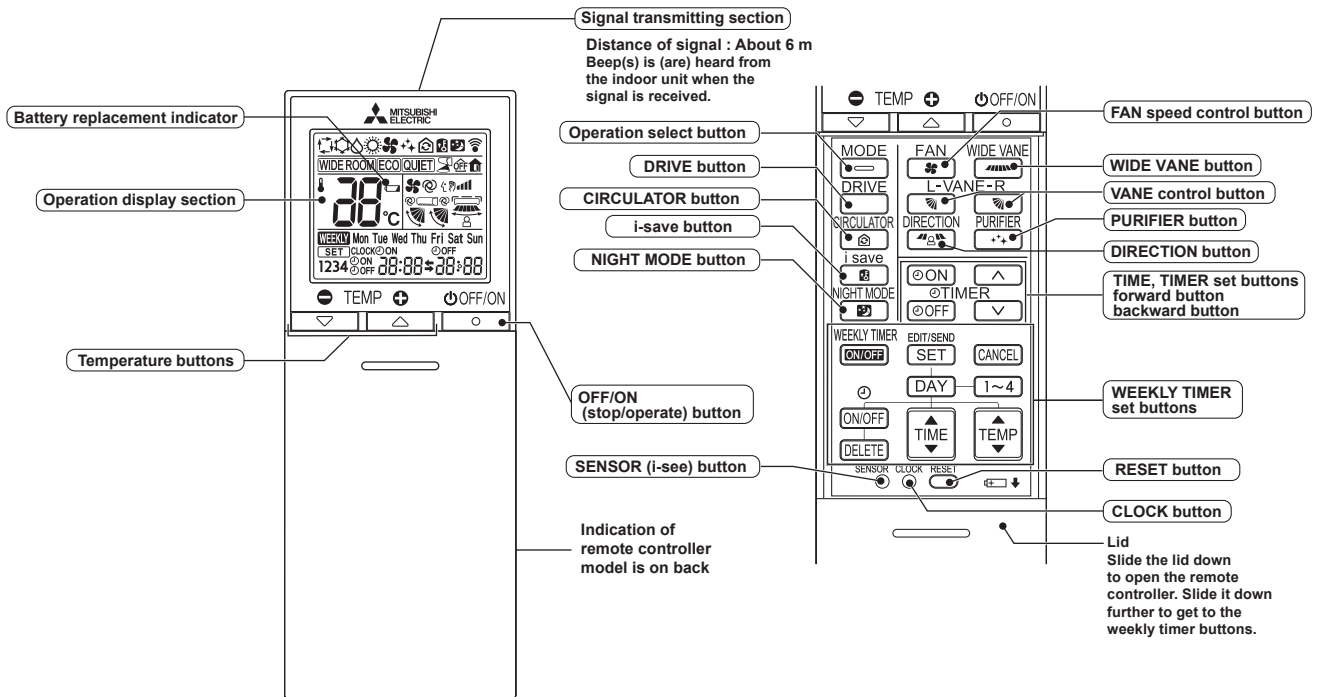



NOTE: Last setting will be stored after the unit is turned OFF with the remote controller. Indoor unit receives the signal of the remote controller with beeps.

INDOOR UNIT DISPLAY SECTION

Operation Indicator lamp

The operation indicator at the right side of the indoor unit indicates the operation state.

•The following indication applies regardless of shape of the indication.

Indication	Operation state	Room temperature
 	Standby mode (Only during multi system operation)	—

-  Lit
-  Blinking
-  Not lit

9-1. COOL (❄️) OPERATION

- (1) Press OFF/ON (stop/operate) button.

OPERATION INDICATOR lamp of the indoor unit turns on with a beep tone.

- (2) Select COOL mode with Operation select button.

- (3) Press Temperature buttons TEMP \ominus or \oplus button to select the desired temperature. The setting range is 16 - 31°C.

1. Coil frost prevention

The compressor operational frequency is controlled by the temperature of the indoor heat exchanger to prevent the coil from frosting.

When the temperature of indoor heat exchanger becomes too low, the coil frost prevention mode works.

The indoor fan operates at the set speed and the compressor stops. This mode continues until the temperature of indoor heat exchanger rises.

2. Low outside temperature operation

When the outside temperature is lower, low outside temperature operation starts, and the outdoor fan slows or stops.

3. Indoor fan speed control

When the thermostat turns OFF, the indoor fan operates very Low to reduce power consumption.

When the room temperature rises and the thermostat is ON, the indoor fan operates according to the settings on the remote controller.

9-2. DRY (☀️) OPERATION

- (1) Press OFF/ON (stop/operate) button.

OPERATION INDICATOR lamp of the indoor unit turns on with a beep tone.

- (2) Select DRY mode with Operation select button.

- (3) The set temperature is determined from the initial room temperature.

1. Coil frost prevention

Coil frost prevention works the same way as that in COOL mode. (9-1.1.)

2. Low outside temperature operation

Low outside temperature operation works the same way as that in COOL mode. (9-1.2.)

3. Indoor fan speed control

Indoor fan speed control works the same way as that in COOL mode. (9-1.3.)

9-3. FAN (🌀) OPERATION

- (1) OPERATION INDICATOR lamp of the indoor unit turns on with a beep tone.

- (2) Select FAN mode with Operation select button.

- (3) Select the desired fan speed. When AUTO, it becomes Low.

Only indoor fan operates.

Outdoor unit does not operate.

9-4. HEAT (🔥) OPERATION

- (1) Press OFF/ON (stop/operate) button.

OPERATION INDICATOR lamp of the indoor unit turns on with a beep tone.

- (2) Select HEAT mode with Operation select button.

- (3) Press Temperature buttons TEMP \ominus or \oplus button to select the desired temperature. The setting range is 10 - 31°C.

1. Cold air prevention control

When the compressor is not operating or is starting, and the temperature of indoor heat exchanger and/or the room temperature is low or when defrosting is being done, the indoor fan will stop or rotate in Very Low speed.

2. High pressure protection

The compressor operational frequency is controlled by the temperature of the indoor heat exchanger to prevent the condensing pressure from increasing excessively.

When the temperature of indoor heat exchanger becomes too high, the high pressure protection works.

The indoor fan operates following the cold air prevention control. This mode continues until the temperature of indoor heat exchanger falls.

3. Defrosting

Defrosting starts when the temperature of outdoor heat exchanger becomes too low.

The compressor stops once, the indoor/outdoor fans stop, the 4-way valve reverses, and the compressor re-starts.

This mode continues until the temperature of outdoor heat exchanger rises or the fixed time passes.

9-5. AUTO CHANGE OVER ... AUTO MODE OPERATION

Once desired temperature is set, unit operation is switched automatically between COOL and HEAT operation.

Mode selection

- (1) Initial mode

When unit starts the operation with AUTO operation from OFF:

- If the room temperature is higher than the set temperature, operation starts in COOL mode.
- If the room temperature is equal to or lower than the set temperature, operation starts in HEAT mode.

- (2) Mode change

COOL mode changes to HEAT mode when about 15 minutes have passed with the room temperature 1°C below the set temperature.

HEAT mode changes to COOL mode when about 15 minutes have passed with the room temperature 1°C above the set temperature.

NOTE 1:

If 2 or more indoor units are operating in multi system, there might be a case that the indoor unit, which is operating in □ (AUTO), cannot change over to the other operating mode (COOL ↔ HEAT) and becomes a state of standby. Refer to **NOTE 2 “FOR MULTI SYSTEM AIR CONDITIONER”**.

NOTE 2:

FOR MULTI SYSTEM AIR CONDITIONER

OUTDOOR UNIT: MXZ series

Multi system air conditioner can connect 2 or more indoor units with one outdoor unit.

- When you try to operate 2 or more indoor units with one outdoor unit simultaneously, one for the cooling and the others for heating, the operation mode of the indoor unit that operates first is selected. Other indoor units cannot operate, and operation indicator lamp blinks as shown in the figure below. In this case, please set all the indoor units to the same operation mode.

OPERATION INDICATOR

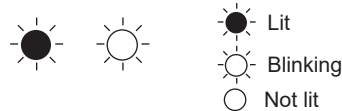

- When indoor unit starts the operation while the defrosting of outdoor unit is being done, it takes a few minutes (max. 10 minutes) to blow out the warm air.
- In the heating operation, though indoor unit that does not operate may get warm or the sound of refrigerant flowing may be heard, they are not malfunction. The reason is that the refrigerant continuously flows into it.

9-6. AUTO VANE OPERATION

1. Horizontal vane

(1) Vane motor drive

These models are equipped with stepping motors for the horizontal vanes. The rotating direction, speed, and angle of the motor are controlled by pulse signals (approximately 12 V) transmitted from indoor microprocessor.

(2) The horizontal vane angle and mode change as follows by pressing VANE CONTROL () button.

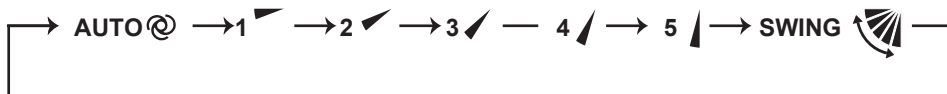

NOTE: The right and left horizontal vanes set to the same level may not align perfectly.

(3) Positioning

To confirm the standard position, the vane moves until it touches the vane stopper. Then the vane is set to the selected angle.

Confirmation of standard position is performed in the following cases:

- (a) When the operation starts or finishes (including timer operation).
- (b) When the test run starts.
- (c) When standby mode (only during multi system operation) starts or finishes.

(4) VANE AUTO (@) mode

In VANE AUTO mode, the microprocessor automatically determines the vane angle to make the optimum room temperature distribution.

In COOL and DRY operation
Vane angle is fixed to Horizontal position.



In HEAT operation
Vane angle is fixed to Angle 4.



(5) STOP (operation OFF) and ON TIMER standby

In the following cases, the horizontal vane returns to the closed position.

- (a) When OFF/ON (stop/operate) button is pressed (POWER OFF).
- (b) When the operation is stopped by the emergency operation.
- (c) When ON TIMER is ON standby.

(6) Dew prevention

During COOL or DRY operation with the lower position when the compressor cumulative operation time exceeds 1 hour, the vane angle automatically changes to Angle 1 for dew prevention.

(7) SWING (🌀) mode

By selecting SWING mode with VANE control button, the horizontal vanes swing vertically.
When COOL, DRY or FAN mode is selected, only the upper vane swings.

(8) Cold air prevention in HEAT operation

The horizontal vane position is set to Upward.

NOTE: When 2 or more indoor units are operated with multi outdoor unit, even if any indoor unit turns thermostat off, this control does not work in the indoor unit.

(9) ECONO COOL (🌀) operation (ECONOmical operation) (MSZ-RW25/35/50VG - E1 only)

When ECONO COOL button is pressed in COOL mode, set temperature is automatically set 2°C higher by the microprocessor. However, the temperature on the LCD screen on the remote controller is not changed. Also the horizontal vane swings in various cycle.

SWING operation makes you feel cooler than set temperature. So, even though the set temperature is higher, the air conditioner can keep comfort. As a result, energy can be saved.

To cancel this operation, select a different mode or press one of the following buttons in ECONO COOL operation: ECONO COOL or VANE control button.

2. Vertical vane

(1) Vane motor drive

These models are equipped with a stepping motor for the vertical vane. The rotating direction, speed, and angle of the motor are controlled by pulse signals (approximately 12 V) transmitted from microprocessor.

(2) The vertical vane angle and mode change as follows by pressing WIDE VANE button.

(3) Positioning

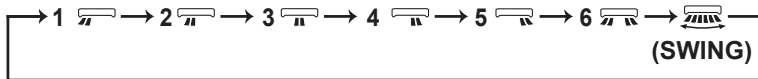

To confirm the standard position, the vane moves until it touches the vane stopper. Then the vane is set to the selected angle.

Confirmation of standard position is performed in the following cases:

(a) OFF/ON (stop/operate) button is pressed (POWER ON).

(4) SWING (🌀) MODE

By selecting SWING mode with WIDE VANE button, the vertical vane swings horizontally. The remote controller displays "🌀". Swing mode is cancelled when WIDE VANE button is pressed once again.

9-7. TIMER OPERATION

1. How to set the time

- (1) Check that the current time is set correctly.

NOTE: Timer operation will not work without setting the current time. Initially "0:00" blinks at the current time display of TIME MONITOR, so set the current time correctly with CLOCK button.

How to set the current time

- (a) Press the CLOCK button.
 (b) Press the TIME set buttons ($\square \wedge$) and ($\square \vee$) to set the current time.
 • Each time forward button ($\square \wedge$) is pressed, the set time increases by 1 minute, and each time backward button ($\square \vee$) is pressed, the set time decreases by 1 minute.
 • Pressing those buttons longer, the set time increases/decreases by 10 minutes.
 (c) Press the CLOCK set button.
 (2) Press OFF/ON (stop/operate) button to start the air conditioner.
 (3) Set the time of timer.

ON timer setting

- (a) Press ON TIMER button (ON) during operation.
 (b) Set the time of the timer using TIME set buttons ($\square \wedge$) and ($\square \vee$).

OFF timer setting

- (a) Press OFF TIMER button (OFF) during operation.
 (b) Set the time of the timer using TIME set buttons ($\square \wedge$) and ($\square \vee$).
 *Each time forward button ($\square \wedge$) is pressed, the set time increases by 10 minutes: each time backward button ($\square \vee$) is pressed, the set time decreases by 10 minutes.

2. To release the timer

To release ON timer, press ON TIMER button (ON).

To release OFF timer, press OFF TIMER button (OFF).

TIMER is cancelled and the display of set time disappears.

PROGRAM TIMER

- OFF timer and ON timer can be used in combination. The set time that is reached first will operate first.
- "➔" and "➔" display shows the order of OFF timer and ON timer operation.

(Example 1) The current time is 8:00 PM.

The unit turns off at 11:00 PM, and on at 6:00 AM.

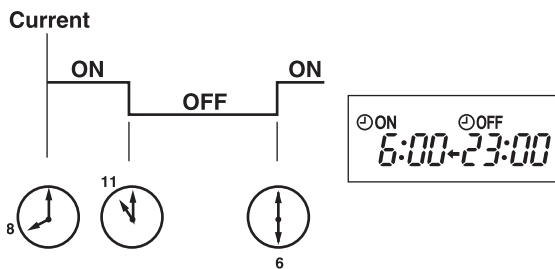

(Example 2) The current time is 11:00 AM.

The unit turns on at 5:00 PM, and off at 9:00 PM.

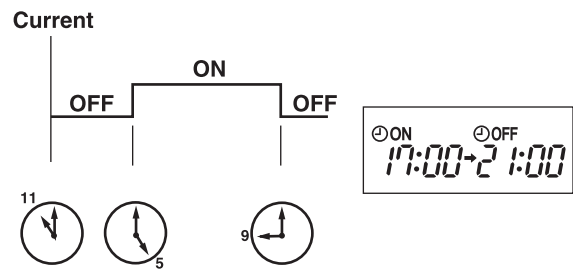

NOTE: If the main power is turned OFF or a power failure occurs while ON/OFF timer is active, the timer setting is cancelled. As these models are equipped with an auto restart function, the air conditioner starts operating with timer cancelled when power is restored.

9-8. WEEKLY TIMER OPERATION

- A maximum of 4 ON or OFF timers can be set for individual days of the week.
- A maximum of 28 ON or OFF timers can be set for a week.

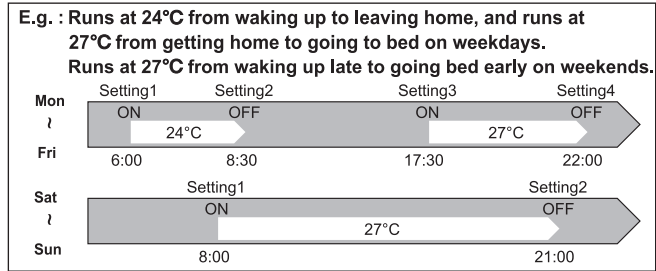

NOTE:

- The simple ON/OFF timer setting is available while the weekly timer is on. In this case, the ON/OFF timer has priority over the weekly timer; the weekly timer operation will start again after the simple ON/OFF timer is complete.

1. How to set the weekly timer

* Make sure that the current time and day are set correctly.

- (1) Press **EDIT/SEND** button to enter the weekly timer setting mode.

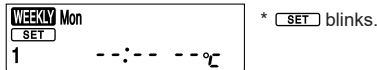

- (2) Press **DAY** and **1~4** buttons to select setting day and number.

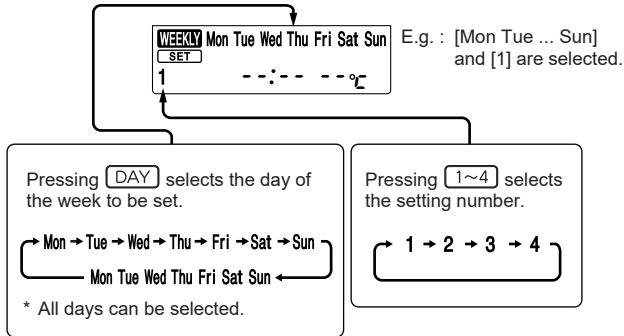

- (3) Press **ON/OFF**, **TIME**, and **TEMP** buttons to set ON/OFF, time, and temperature.

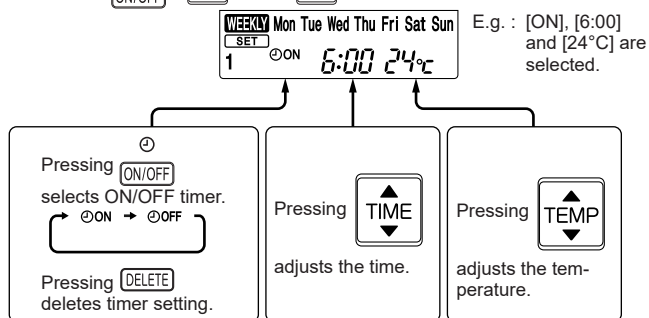

* Hold down the button to change the time quickly.

* The temperature can be set between 16°C and 31°C at COOL operation.

* The temperature can be set between 10°C and 31°C at HEAT operation.





Press **DAY** and **1~4** buttons to continue setting the timer for other days and/or numbers.



(4) Press  button to complete and transmit the weekly timer setting.





*  which was blinking goes out, and the current time will be displayed.

NOTE:

- Press  button to transmit the setting information of weekly timer to the indoor unit. Point the remote controller toward the indoor unit for 3 seconds.
- When setting the timer for more than one day of the week or one number,  button does not have to be pressed per each setting. Press  button once after all the settings are completed. All the weekly timer settings will be saved.
- Press  button to enter the weekly timer setting mode, and press and hold  button for 5 seconds to erase all weekly timer settings. Point the remote controller toward the indoor unit.

(5) Press  button to turn the weekly timer ON. ()

•When the weekly timer is ON, the day of the week whose timer setting is completed, will light.

Press  button again to turn the weekly timer OFF. ()



NOTE:

The saved settings will not be cleared when the weekly timer is turned OFF.

2. Checking weekly timer setting

(1) Press  button to enter the weekly timer setting mode.

* blinks.

(2) Press  or  buttons to view the setting of the particular day or number.

(3) Press  button to exit the weekly timer setting.

NOTE:

When all days of the week are selected to view the settings and a different setting is included among them,  will be displayed.

9-9. i-see CONTROL () MODE AND ABSENCE DETECTION

In the i-see control mode, the room temperature is controlled based on the sensible temperature.

(1) Press SENSOR button with a thin instrument during COOL, DRY, HEAT and AUTO mode to activate i-see control mode ().
The default setting is “active”.

(2) Press SENSOR button several times to cancel i-see control mode.

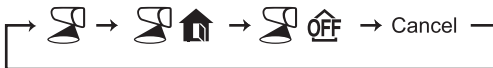

NOTE:

How to detect human presence

- When the air conditioner starts to operate, the i-see Sensor analyzes the temperature of a room by rotating clockwise and counterclockwise.
- Then, it detects human presence by their motion based on their heat signatures.



Detection range

The i-see Sensor does not analyze the temperature in the following range.

- The wall surface on which the air conditioner is installed
- The spot beneath the air conditioner
- Where there is an object (such as furniture) between the place and the air conditioner

It might not detect human and objects properly on the following conditions

- When the temperature of the floor and the wall is high (such as when the air conditioner starts to operate in summer)
- When occupants are in blanket or wear heavily
- When there is an object whose temperature changes rapidly in a short time
- When windows and doors are small or they are far from the air conditioner
- When the sensor cannot detect the heat source such as of small kids or pets
- When using a floor heating or an electric carpet
- When occupants do not move after the air conditioner starts to operate

Refer to the following “Absence Detection” for  and .

ABSENCE DETECTION (🏠)

This function automatically changes the operation to No occupancy energy-saving mode or No occupancy Auto-OFF mode when nobody is in the room.

- (1) To activate this No occupancy energy-saving mode, press SENSOR button until 🏠 appears on the operation display of the remote controller.
- (2) To activate this No occupancy Auto-OFF mode, press SENSOR button until OFF appears on the operation display of the remote controller.
- (3) Press SENSOR button again to cancel the ABSENCE DETECTION.

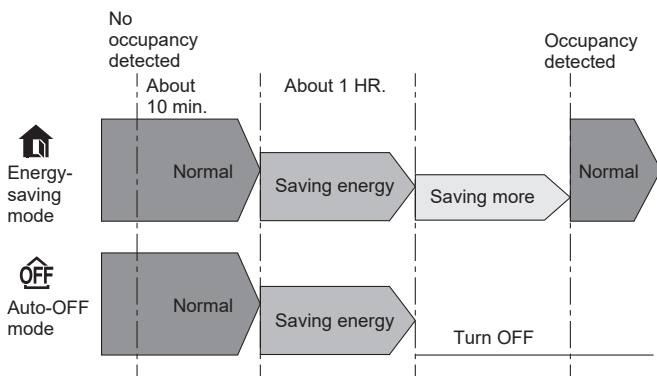
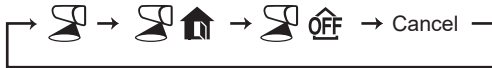

- Even if the unit is turned OFF due to No occupancy Auto-OFF mode, the display of the remote controller remains to indicate the unit is in operation. Press STOP/OPERATE(OFF/ON) button then press STOP/OPERATE(OFF/ON) button again to restart operation.
- When OFF timer is set, a priority is given to OFF timer.
- The unit will not be turned off if no one is detected during normal operation mode, even though No occupancy Auto-OFF mode is activated.

9-10. AIRFLOW CONTROL MODE

AIRFLOW CONTROL mode offers air conditioning according to a location of an occupant in a room detected by i-see SENSOR.

- (1) Press DIRECTION button during COOL, DRY, HEAT or AUTO mode to activate the AIRFLOW CONTROL mode. This mode is only available when the i-see control mode is effective.
- (2) Each press of DIRECTION button changes AIRFLOW CONTROL in the following order:

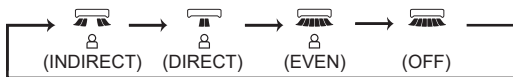

(INDIRECT) : An occupant will be less exposed to direct airflow.

(DIRECT) : Mainly the vicinity of an occupant will be air-conditioned.

(EVEN) : The unit learns the area where an occupant spend most of the time, and evens out the temperature of that area.

NOTE:

- Horizontal and vertical airflow directions will be automatically selected.
 - When more than a couple of people are in a room, the AIRFLOW CONTROL mode may work less effectively.
 - If you still feel uncomfortable with the air direction determined by the INDIRECT mode, adjust the air direction manually.
- (3) Cancelling the i-see control mode automatically cancels the AIRFLOW CONTROL mode.
 - The AIRFLOW CONTROL mode is also cancelled when the VANE control or WIDE VANE buttons is pressed.

9-11. NIGHT MODE (🌙) OPERATION

NIGHT MODE changes the brightness of the operation indicator, disables the beep sound and limits the noise level of the outdoor unit.

- (1) Press NIGHT MODE button during operation to activate NIGHT mode (🌙).
 - The operation indicator lamp dims.
 - The beep sound will be disabled except that emitted when the operation is started or stopped.
 - Noise level of the outdoor unit will be lower than that mentioned in SPECIFICATIONS. (Except the connection to MXZ.)
- (2) Press NIGHT MODE button to cancel NIGHT mode (🌙).

NOTE:

- Noise level of the outdoor unit may not change after startup of the unit, during the protection operation, or depending on other operating conditions.
- The fan speed of the indoor unit will not change.
- The operation indicator lamp will be hard to be seen in a bright room.
- Noise level of the outdoor unit will not decrease during Multi system operation.

9-12. AIR PURIFYING (🌿) OPERATION

In the AIR PURIFYING operation, the indoor unit built-in device reduces airborne fungi, viruses, mold, and allergens.

- (1) Press PURIFIER button to start AIR PURIFYING operation.
 - AIR PURIFYING lamp turns on. (Display section)
- (2) Press PURIFIER button again to cancel AIR PURIFYING operation.
 - AIR PURIFYING lamp turns off. (Display section)

NOTE:

- Never touch the air purifying device during operation. Although the air purifying device is safety-conscious design, touching this device could be the cause of trouble as this device discharge high voltage electricity.
- A "hissing" sound may be heard during the air purifying operation. This sound is produced when plasma is being discharged. This is not a malfunction.
- AIR PURIFYING lamp does not turn on if the front panel is not closed completely.

9-13. i-save (🔒) OPERATION

1. How to set i-save operation

- (1) Press OFF/ON (stop/operate) button.
- (2) Select COOL, CIRCULATOR, HEAT, ECONO COOL, or NIGHT mode.
- (3) Press i-save button.
- (4) Set the temperature, fan speed, and airflow direction for i-save operation.

NOTE:



- i-save operation cannot be selected during DRY, FAN or AUTO mode operation.
- The setting range of HEAT mode i-save operation is 10 - 31°C.
- 2 groups of setting can be saved. (One for COOL/ECONO COOL/CIRCULATOR, one for HEAT)

2. How to cancel operation



- Press i-save button again.
- i-save operation can also be cancelled by pressing Operation select button to change the operation mode. The preferred setting can be saved for the next time with a single press of i-save button.



9-14. OPERATION LOCK

This function locks operation mode only. Other functions, such as OFF/ON, temperature setting, or airflow direction adjustment, are available.

- (1) Hold down  button and  button simultaneously for 2 seconds while the unit is not operating to enable OPERATION LOCK.

The icon for the locked operation mode blinks.

- (2) Hold down  button and  button simultaneously for 2 seconds again while the unit is not operating to disable OPERATION LOCK.

- The icon for the locked operation mode blinks when  button and  button are held down to enable or disable OPERATION LOCK or  button is pressed during operation while OPERATION LOCK is enabled.
- AIR PURIFYING operation is not available when OPERATION LOCK is enabled in a mode other than FAN mode.

9-15. CIRCULATOR OPERATION (MSZ-RW25/35/50VG - [SC1] only)

In case the indoor temperature reaches the setting temperature, the outdoor unit stops and the indoor unit starts FAN operation to circulate the indoor air.

The setting of fan speed and airflow direction can be changed.

The outdoor unit starts operation automatically when the indoor temperature drops below the setting temperature.

(1) Press CIRCULATOR button during HEAT mode to enable CIRCULATOR operation.

The unit performs FAN operation in case the indoor temperature reaches the setting temperature.

(2) Set the fan speed and airflow direction.

- The setting of fan speed and airflow direction is common for HEAT and CIRCULATOR operation.
- Ventilation starts at Low fan speed in case AUTO fan speed is selected.

(3) Press CIRCULATOR button again to cancel CIRCULATOR operation.

NOTE:

CIRCULATOR operation doesn't work in the following situation.

- AUTO mode (Auto change over) is selected.
- Defrosting is being done.
- Indoor unit is connected to multi type outdoor unit.

Although received sound will be heard from the indoor unit and mark is displayed on remote controller when is pushed, CIRCULATOR operation doesn't work in multi connection.

- FAN operation may make you feel cold wind.

Reduce the FAN speed or adjust the airflow direction to avoid the wind.

9-16. DRIVE MODE SELECTOR

1. How to set DRIVE mode selector

(1) Select a desired mode from WIDE ROOM, ECO, or QUIET.

(2) Press DRIVE button during COOL and HEAT mode to activate the DRIVE mode.

(3) Press DRIVE button several times to cancel the DRIVE MODE.



The details of each mode are as follows:

WIDE ROOM

Increases air volume and delivers airflow to a longer distance, reducing temperature unevenness in the room.

QUIET

- Decreases air volume and lowers the operating sound level of the unit.

ECO

- Suppresses a maximum capacity and operates efficiently without an excessive power consumption even when a room temperature suddenly changes.

NOTE:

- WIDE ROOM mode increases operating sound level due to the air volume increase.
- QUIET mode and ECO mode can affect heating and cooling performance.
- ECO mode cannot be activated when connected to a multi-system outdoor unit.
- Cancel the mode if you feel uncomfortable after setting.

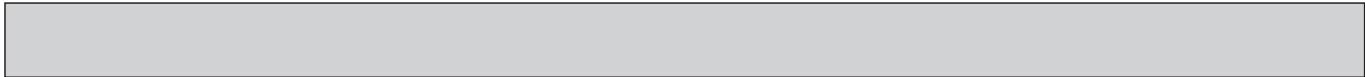

9-17. EMERGENCY/TEST OPERATION

In the case of test run operation or emergency operation, use the emergency operation switch on the right side of the indoor unit. Emergency operation is available when the remote controller is missing or has failed, or when the batteries in the remote controller are running down. The unit will start and OPERATION INDICATOR lamp will light up.

The first 30 minutes of operation is the test run operation. This operation is for servicing. The indoor fan runs at High speed and the temperature control does not work.

After 30 minutes of test run operation, the system shifts to EMERGENCY COOL/HEAT MODE with a set temperature of 24°C.

The fan speed shifts to Med.

The coil frost prevention works even in the test run or the emergency operation.

In the test run or emergency operation, the horizontal vane operates in VANE AUTO (@) mode.

Emergency operation continues until the emergency operation switch is pressed once or twice or the unit receives any signal from the remote controller. In the latter case, normal operation will start.

NOTE: Do not press the emergency operation switch during normal operation.

Operation mode	COOL/HEAT
Set temperature	24°C
Fan speed	Med.
Horizontal vane	Auto

The operation mode is indicated by the Operation Indicator lamp as following

Operation indicator lamp

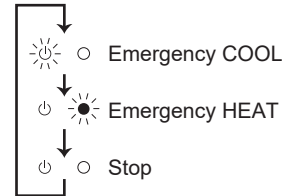

Emergency operation switch (E.O. SW)

9-18. 3-MINUTE TIME DELAY OPERATION

When the system turns OFF, compressor will not restart for 3 minutes as 3-minute time delay function operates to protect compressor from overload.

**MSZ-RW25VG
MSZ-RW35VG
MSZ-RW50VG**

10-1. CAUTIONS ON TROUBLESHOOTING

1. Before troubleshooting, check the following

- 1) Check the power supply voltage.
- 2) Check the indoor/outdoor connecting wire for miswiring.

2. Take care of the following during servicing

- 1) Before servicing the air conditioner, be sure to turn OFF the main unit first with the remote controller, and then after confirming the horizontal vane is closed, turn OFF the breaker and/or disconnect the power plug.
- 2) Be sure to turn OFF the power supply before removing the front panel, the cabinet, the top panel, and the P.C. board.
- 3) When removing the P.C. board, hold the edge of the board with care NOT to apply stress on the components.
- 4) When connecting or disconnecting the connectors, hold the connector housing. DO NOT pull the lead wires.

<Incorrect>



Lead wiring

<Correct>



Connector housing

3. Troubleshooting procedure

- 1) Check if the OPERATION INDICATOR lamp on the indoor unit is blinking ON and OFF to indicate an abnormality. To make sure, check how many times the OPERATION INDICATOR lamp is blinking ON and OFF before starting service work.
- 2) Before servicing, verify that all connectors and terminals are connected properly.
- 3) When the electronic control P.C. board seems to be defective, check for disconnection of the copper foil pattern and burnt or discolored components.
- 4) When troubleshooting, Refer to 10-2, 10-3 and 10-4.

4. How to replace batteries

Weak batteries may cause the remote controller malfunction.

In this case, replace the batteries to operate the remote controller normally.

- ① Remove the front lid and insert batteries. Then reattach the front lid.

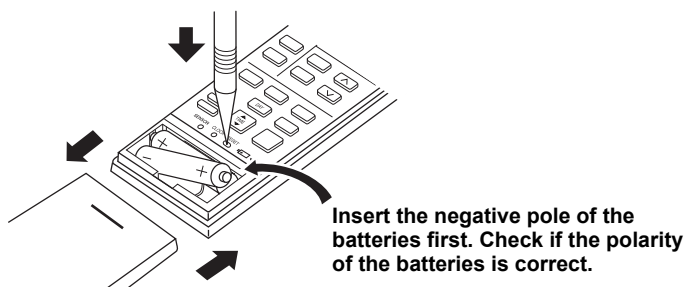

- ② Press RESET button with a thin instrument, and then use the remote controller.

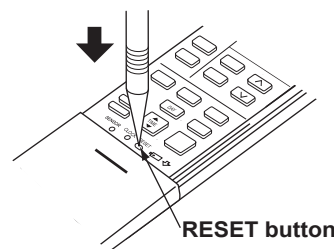

- NOTE:**
1. If RESET button is not pressed, the remote controller may not operate correctly.
 2. This remote controller has a circuit to automatically reset the microprocessor when batteries are replaced. This function is equipped to prevent the microprocessor from malfunctioning due to the voltage drop caused by the battery replacement.
 3. Do not use the leaking batteries.

10-2. FAILURE MODE RECALL FUNCTION

Outline of the function

This air conditioner can memorize the abnormal condition which has occurred once.

Even though LED indication listed on the troubleshooting check table (10-4.) disappears, the memorized failure details can be recalled.

1. Flow chart of failure mode recall function for the indoor/outdoor unit

NOTE: The indoor unit does not operate by smartphone, refer to 10-3.2."Check of Wi-Fi module".

Operational procedure

MSZ-RW25/35/50VG - [E1]

MSZ-RW25/35/50VG - [SC1]

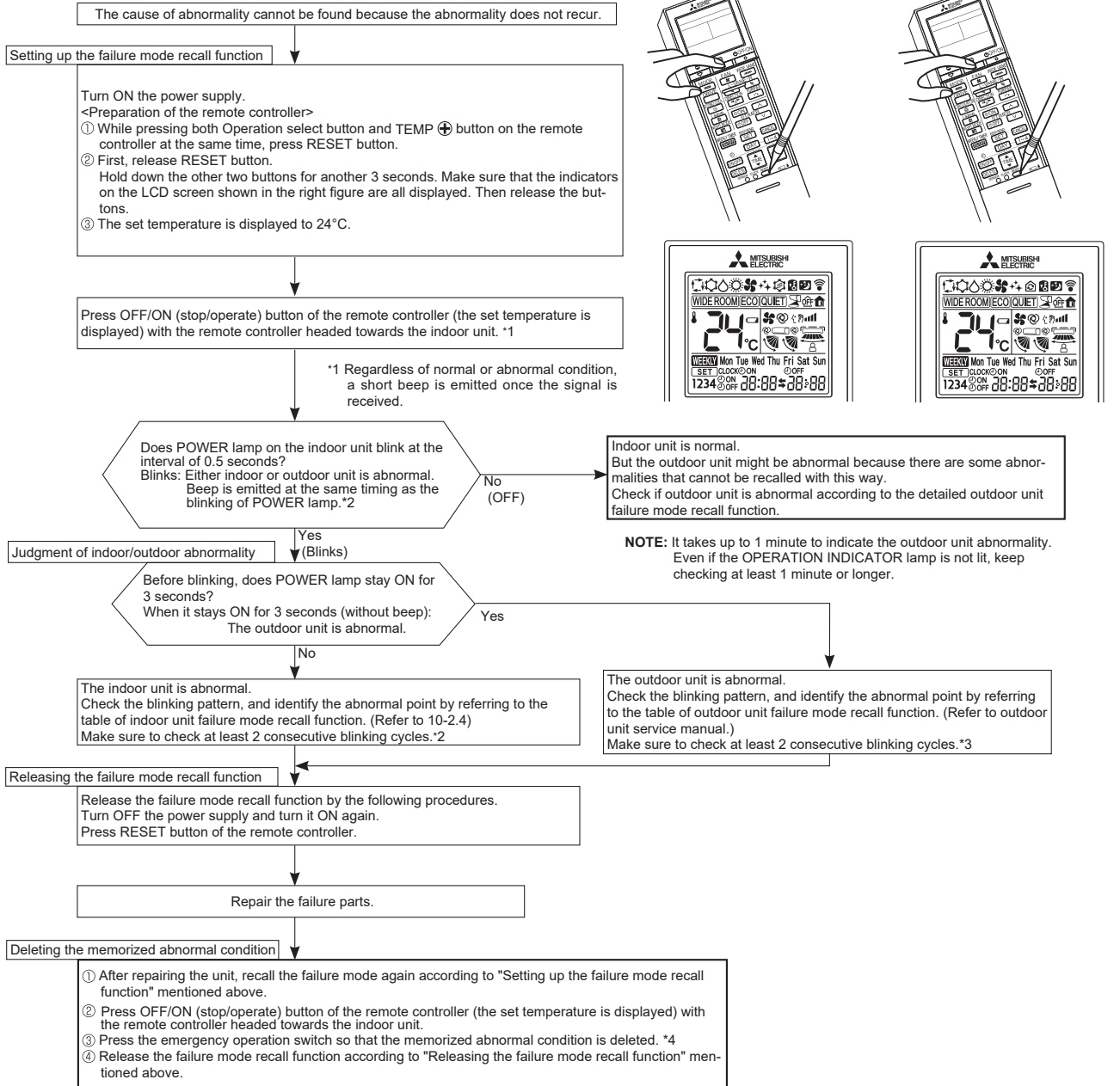

NOTE: 1. Make sure to release the failure mode recall function after it is set up, otherwise the unit cannot operate properly.
2. If the abnormal condition is not deleted from the memory, the last abnormal condition is kept memorized.

*2. Blinking pattern when the indoor unit is abnormal:

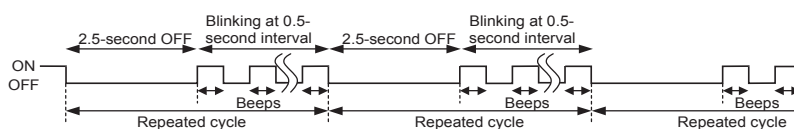

*3. Blinking pattern when the outdoor unit is abnormal:

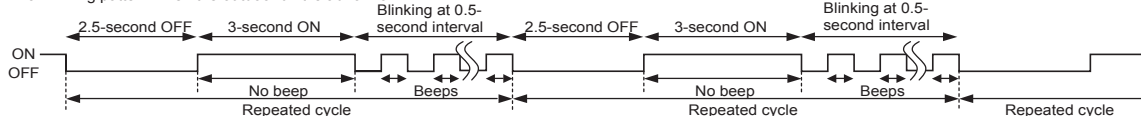

*4 The information regarding whether the connected outdoor unit is a low-standby-power model or a non-low-standby-power model will also be initialized. (Default= compatible with a low-standby-power model)

2. Flow chart of AIR PURIFYING power failure mode and i-see SENSOR failure mode recall function

Operational procedure

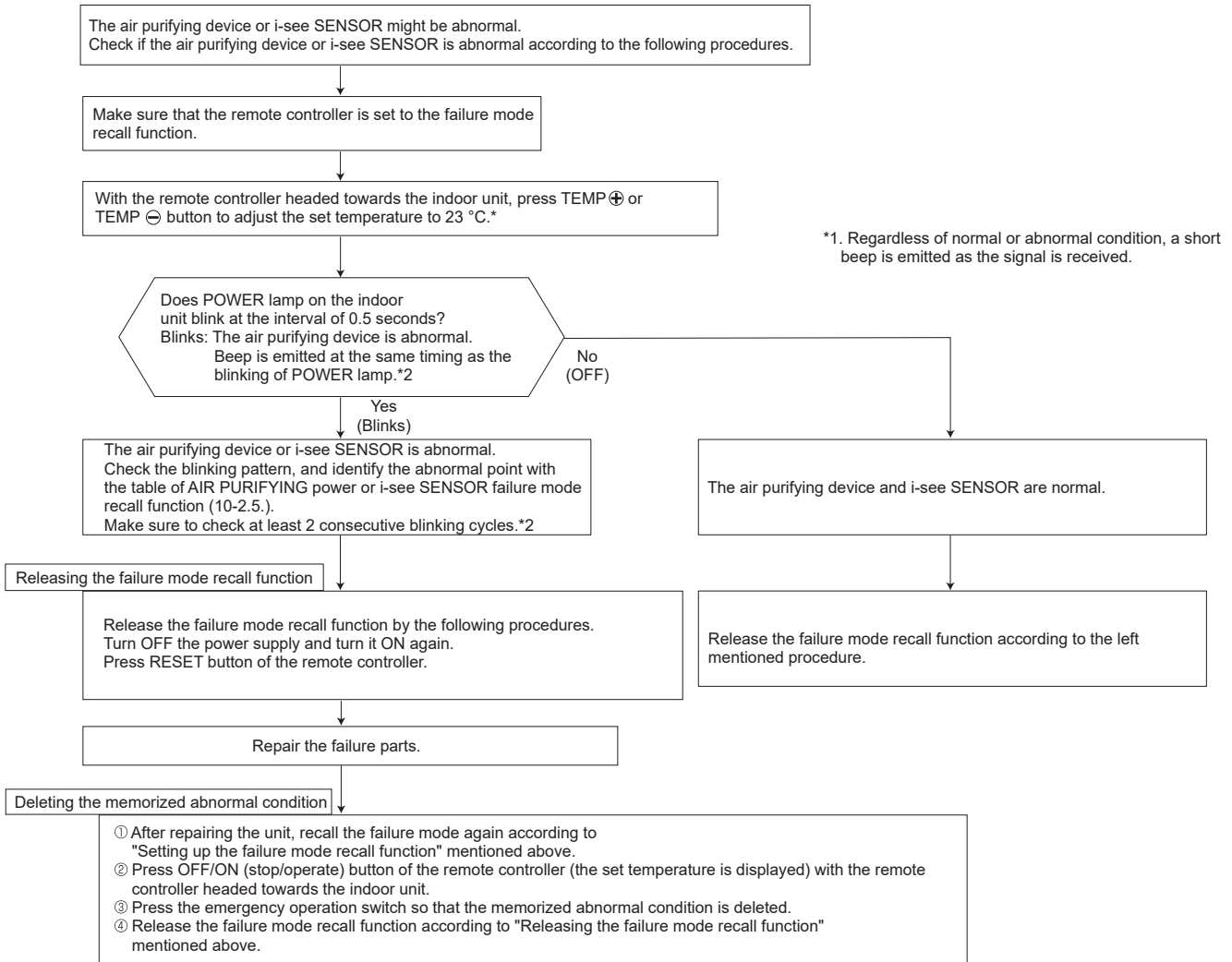

Note1. Make sure to release the failure mode recall function after it is set up, otherwise the unit cannot operate properly.
2. If the abnormal condition is not deleted from the memory, the last abnormal condition is kept memorized.

*2. Blinking pattern when the air purifying device is abnormal:

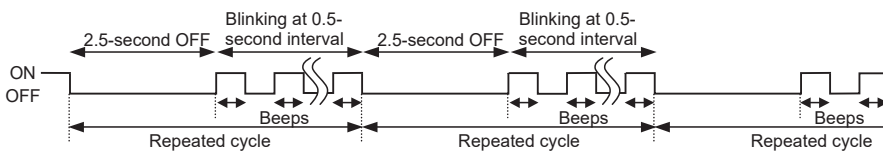

3. AIR PURIFYING power operation check

AIR PURIFYING power operation goes ON when PURIFIER button on the remote controller is pressed with any set temperature displayed during failure mode recall function. Check the operation display section of the remote controller to confirm that AIR PURIFYING power operation is activated. While AIR PURIFYING lamp stays OFF, it means normal. Blinking AIR PURIFYING lamp means abnormal, the AIR PURIFYING power operation is not conducted.

AIR PURIFYING lamp	Remedy
Continuously blinking	Follow "Check of AIR PURIFYING power" to identify the error. (Refer to 10-6.Ⓔ.)
2-time blink	AIR PURIFYING power control circuit on the indoor electronic control P.C. board is out of order. (Refer to 10-6.Ⓔ.)

NOTE: Perform the above mentioned check with the front panel closed. The interlock switch (Air purifying device) works by opening front panel and the AIR PURIFYING power is cut.



4. Table of indoor unit failure mode recall function (When recalled at a set temperature of 24°C)

POWER lamp	Abnormal point (Failure mode)	Condition	Remedy
Not lit	Normal	—	—
1-time blink every 0.5-second	Room temperature thermistor	The room temperature thermistor short or open circuit is detected every 8 seconds during operation.	Refer to the characteristics of the room temperature thermistor (10-7.).
2-time blink 2.5-second OFF	Indoor coil thermistor	The indoor coil thermistor short or open circuit is detected every 8 seconds during operation.	Refer to the characteristics of the main indoor coil thermistor, the sub indoor coil thermistor (10-7.).
3-time blink 2.5-second OFF	Serial signal	The serial signal from outdoor unit is not received for a maximum of 6 minutes.	Refer to 10-6.Ⓒ "How to check miswiring and serial signal error".
11-time blink 2.5-second OFF	Indoor fan motor	The rotational frequency feedback signal is not emitted for 12 seconds after the indoor fan motor is operated	Refer to 10-6.Ⓐ "Check of indoor fan motor".
12-time blink 2.5-second OFF	Indoor control system	It cannot properly read data in the nonvolatile memory of the indoor electronic control P.C. board.	Replace the indoor electronic control P.C. board.

NOTE: Blinking patterns of this mode differ from the ones of TROUBLESHOOTING CHECK TABLE (10-4.).

5. Table of indoor unit failure mode recall function (When recalled at a set temperature of 23°C)

Table of AIR PURIFYING power failure mode recall function

POWER lamp	Abnormal point (Failure mode)	Condition	Remedy
1-time blink	AIR PURIFYING power control	When AIR PURIFYING power cannot be turned OFF even if the AIR PURIFYING operation is turned OFF with the remote controller.	Refer to 10-6.Ⓒ "Check of AIR PURIFYING power".
2-time blink	Electrode (Spark discharge)	When the voltage between CN1T1 Ⓒ(+) and Ⓓ(Ⓔ) on the electronic P.C. board falls below 1.3V (spark discharge judgment voltage).	
3-time blink	Electrode (Abnormal electric discharge error 1)	When the voltage between CN1T1 Ⓒ(+) and Ⓓ(Ⓔ) on the electronic P.C. board falls by 1.2V below the normal voltage value (2.5V).	
4-time blink	Electrode (Abnormal electric discharge error 2)	When the voltage between CN1T1 Ⓒ(+) and Ⓓ(Ⓔ) on the electronic P.C. board falls significantly. (0.4V / 0.5ms)	
5-time blink	AIR PURIFYING power	When the voltage between CN1T1 Ⓒ(+) and Ⓓ(Ⓔ) on the electronic P.C. board rises above 3V.	

NOTE1 : Blinking patterns of this mode differ from the ones of TROUBLESHOOTING CHECK TABLE (10-4.).

NOTE2 : As soon as an abnormality is detected, AIR PURIFYING power goes OFF, therefore measuring instrument which records the voltage wave is required in order to perform the above mentioned voltage measurement.

Table of i-see SENSOR failure mode recall function

POWER lamp	Abnormal point (Failure mode)	Condition	Remedy
6-time blink	i-see SENSOR	Poor contact in i-see SENSOR wiring Failure in loading corrected data of i-see SENSOR	Check for disconnection of the connectors.

NOTE: Blinking patterns of this mode differ from the ones of TROUBLESHOOTING CHECK TABLE (10-4.).

6. Operation check on i-see SENSOR

While recalling the failure details, set the temperature to 19°C to perform the simple check on the i-see SENSOR. Place your hand over the i-see SENSOR, and the buzzer will beep at 1 second intervals. (Normal detection temperature range is 34 to 39°C.)
If the buzzer does not beep, check for disconnection of the connectors.
Set the temperature to 24°C to exit the simple check mode on the i-see SENSOR.

10-3. INSTRUCTION OF TROUBLESHOOTING

1. Check of the unit.

*1 "Test Run operation" means the operation within 30 minutes after the emergency operation switch is pressed.

*2 There is possibility that diesel explosion may occur due to the air mixed in the refrigerant circuit.
 First, ensure that there are no leakage points on the valves, flare connections, etc. that allow the air to flow into the refrigerant circuit, or no blockage points (e.g. clogged or closed valves) in the refrigerant circuit that cause an increase in pressure.
 If there is no abnormal point like above and the system operates cooling and heating modes normally, the indoor thermistor might have a problem, resulting in false detection.
 Check both the indoor coil thermistor and the room temperature thermistor, and replace faulty thermistor(s), if any.
 (Do not start the operation again without repair to prevent hazards.)

If blinking of OPERATION INDICATOR lamp cannot be checked, it can be checked with failure mode recall function.

NOTE: The indoor unit does not operate by smartphone, refer to 10-3.2."Check of Wi-Fi module".

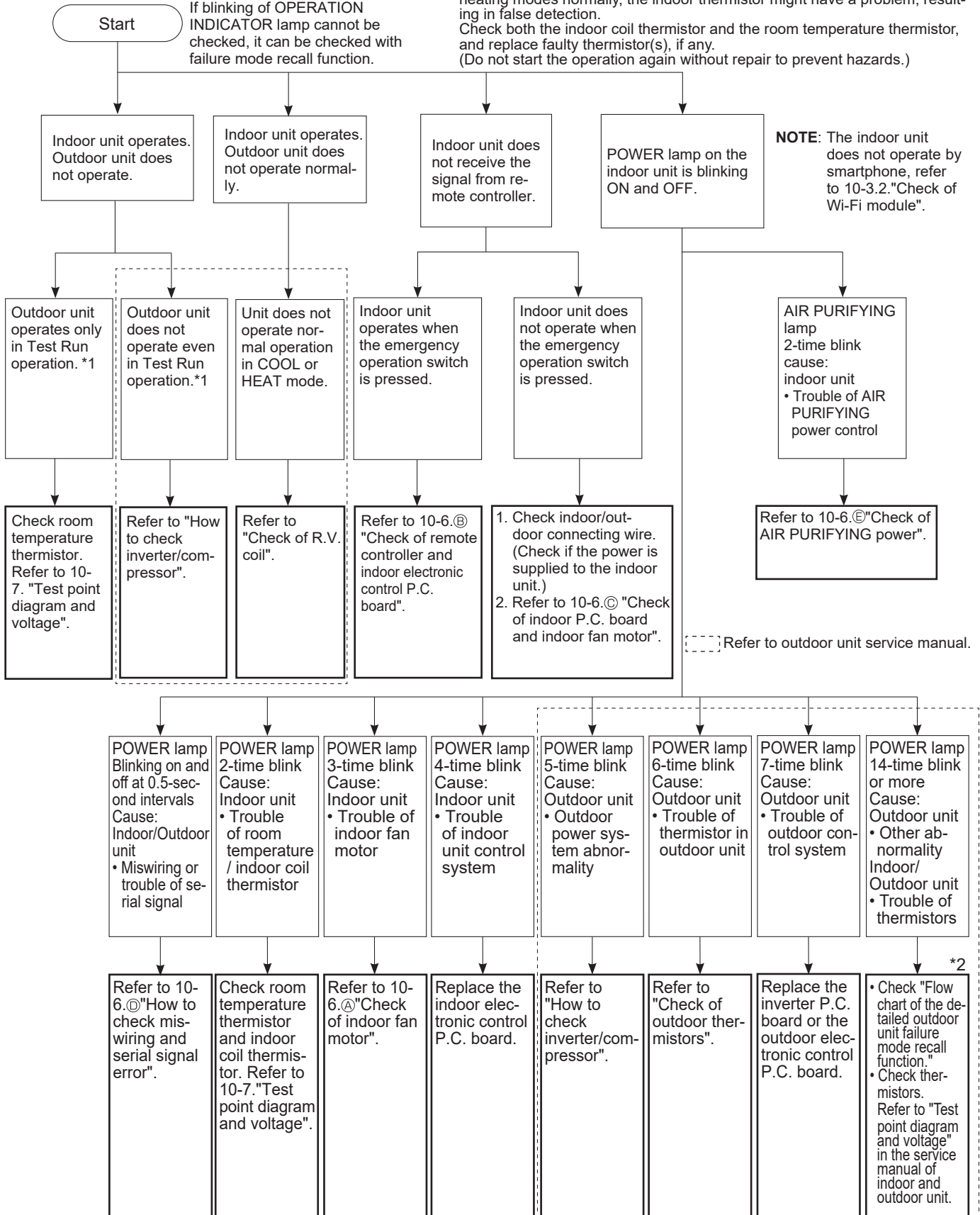

2. Check of Wi-Fi module

Follow the procedure below if the air conditioner cannot be monitored or controlled with a device such as a smartphone.

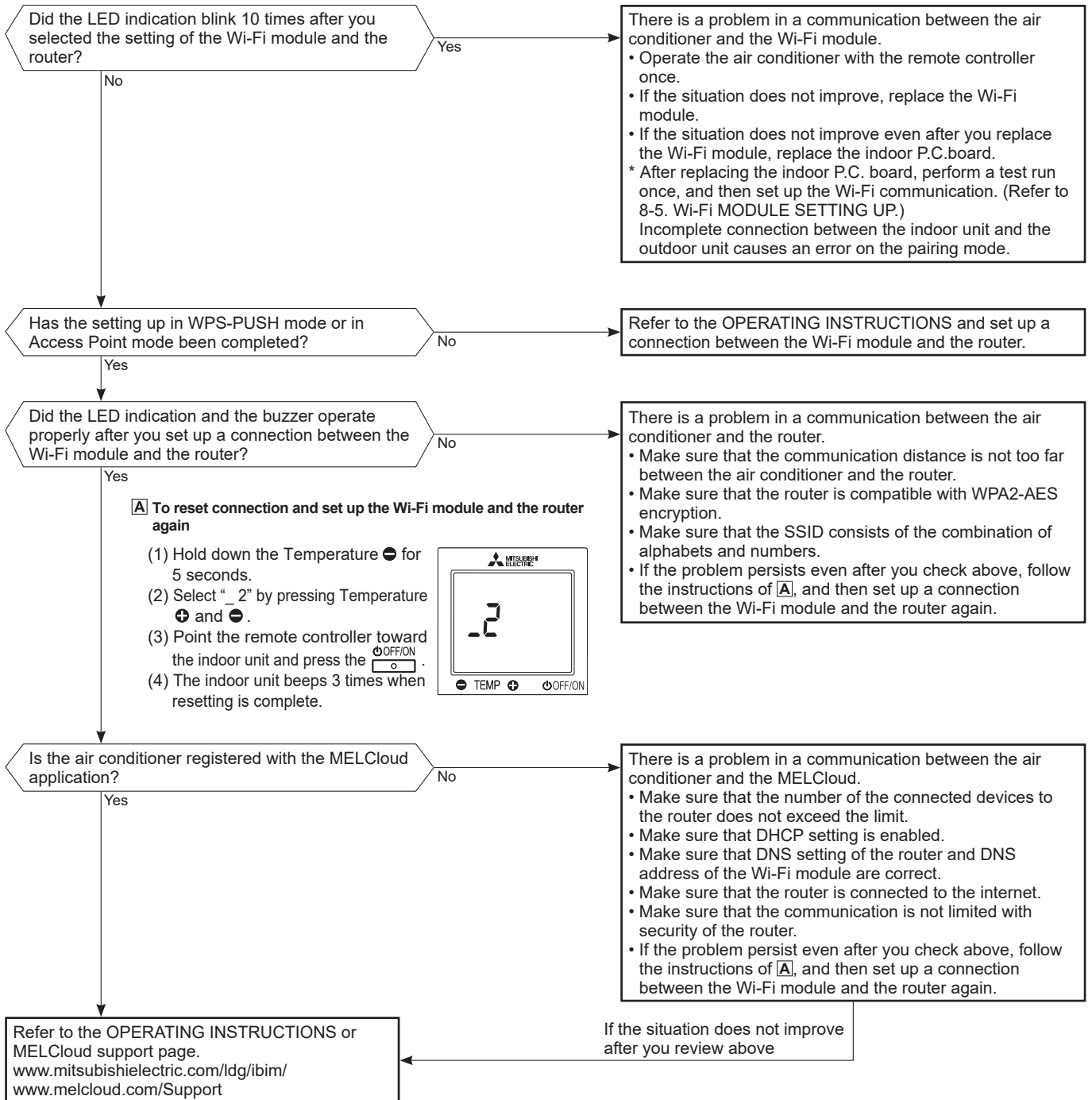

10-4. TROUBLESHOOTING CHECK TABLE

Before taking measures, make sure that the symptom reappears for accurate troubleshooting.

When the indoor unit has started operation and detected an abnormality of the following condition (the first detection after the power ON), the indoor fan motor turns OFF and OPERATION INDICATOR lamp blinks.

• The following indicator applies regardless of shape of the indication.

OPERATION INDICATOR



No.	Abnormal point	Operation indicator lamp	Symptom	Condition	Remedy
1	Miswiring or serial signal	POWER lamp blinks. 0.5-second ON ●○●○●○●○ 0.5-second OFF		The serial signal from the outdoor unit is not received for 6 minutes. The indoor unit is connected to a low-standby-power model after once connected to a non-low-standby-power model.	<ul style="list-style-type: none"> Refer to 10-6. ③ "How to check miswiring and serial signal error". Refer to NOTE.
2	Indoor coil thermistor Room temperature thermistor	POWER lamp blinks. 2-time blink ●○●○●○●○●○●○●○ 2.5-second OFF		The indoor coil or the room temperature thermistor is short or open circuit.	<ul style="list-style-type: none"> Refer to the characteristics of indoor coil thermistor, and the room temperature thermistor (10-7).
3	Indoor fan motor	POWER lamp blinks. 3-time blink ●○●○●○●○●○●○●○●○ 2.5-second OFF		The rotational frequency feedback signal is not emitted during the indoor fan operation.	<ul style="list-style-type: none"> Refer to 10-6. ④ "Check of indoor fan motor".
4	Indoor control system	POWER lamp blinks. 4-time blink ●○●○●○●○●○●○●○●○●○ 2.5-second OFF		It cannot properly read data in the nonvolatile memory of the indoor electronic control P.C. board.	<ul style="list-style-type: none"> Replace the indoor electronic control P.C. board.
5	Outdoor power system	POWER lamp blinks. 5-time blink ●○●○●○●○●○●○●○●○●○ 2.5-second OFF	Indoor unit and outdoor unit do not operate.	It consecutively occurs 3 times that the compressor stops for overcurrent protection or startup failure protection within 1 minute after startup.	<ul style="list-style-type: none"> Refer to "How to check of inverter/compressor". Refer to outdoor unit service manual Check the stop valve.
6	Outdoor thermistors	POWER lamp blinks. 6-time blink ●○●○●○●○●○●○●○●○●○ 2.5-second OFF		The outdoor thermistors short or open circuit during the compressor operation.	<ul style="list-style-type: none"> Refer to "Check of outdoor thermistor". Refer to outdoor unit service manual.
7	Outdoor control system	POWER lamp blinks. 7-time blink ●○●○●○●○●○●○●○●○●○ 2.5-second OFF		It cannot properly read data in the nonvolatile memory of the inverter P.C. board or the outdoor electronic control P.C. board.	<ul style="list-style-type: none"> Replace the inverter P.C. board or the outdoor electronic control P.C. board. Refer to outdoor unit service manual.
8	Other abnormality *2 on 10-3	POWER lamp blinks. 14-time blink or more ●○●○●○●○●○●○●○●○●○●○●○●○ 2.5-second OFF		An abnormality other than the above is detected. An abnormality of the indoor thermistors, the defrost thermistor or ambient temperature thermistor is detected.	<ul style="list-style-type: none"> Check the stop valve. Check the 4-way valve. Check the abnormality in detail using the failure mode recall function for outdoor unit. Refer to TEST POINT DIAGRAM AND VOLTAGE" on the service manual of indoor and outdoor unit for the characteristics of the thermistors. (Do not start the operation again without repair to prevent hazards.)
9	Outdoor control system	POWER lamp lights up. ●	Outdoor unit does not operate	It cannot properly read data in the nonvolatile memory of the inverter P.C. board or the outdoor electronic control P.C. board.	<ul style="list-style-type: none"> Check the blinking pattern of the LED on the inverter P.C. board or the outdoor electronic control P.C. board.

NOTE: The indoor unit may have been connected to a non-low-standby-power model outdoor unit. To use a low-standby-power model, clear the error history by referring to "Deleting the memorized abnormal condition" described in 10-2.1. When the error history is being cleared, the connection information also will be initialized. The indoor unit will be compatible with a low-standby-power model after initialization. If the operation indicator lamp continues to blink as shown in No.1 after the procedure, refer to 10-6. ③ "How to check miswiring and serial error".

OPERATION INDICATOR



(POWER)



(AIR PURIFYING)



Lit



Blinking



Not lit

No.	Abnormal point	Operation indicator lamp	Symptom	Condition	Remedy
1	MXZ type Operation mode setting	<ul style="list-style-type: none"> AIR PURIFYING lamp blinks. <ul style="list-style-type: none"> POWER lamp is lit. 	Outdoor unit operates but indoor unit does not operate.	The operation mode of the each indoor unit is differently set to COOL (includes DRY, FAN) and HEAT at the same time, the operation mode of the indoor unit that has operated at first has the priority.	<ul style="list-style-type: none"> Unify the operation mode. Refer to outdoor unit service manual.

OPERATION INDICATOR



(POWER)



(AIR PURIFYING)



Lit



Blinking



Not lit

No.	Abnormal point	Operation indicator lamp	Symptom	Condition	Remedy
1	AIR PURIFYING power control	<ul style="list-style-type: none"> AIR PURIFYING lamp blinks. 	Indoor unit and outdoor unit do not operate.	When AIR PURIFYING power cannot be turned OFF even if the AIR PURIFYING operation is turned OFF by remote controller.	<ul style="list-style-type: none"> Refer to 10-6.⑥ "Check of AIR PURIFYING power".

10-5. TROUBLESHOOTING CRITERION OF MAIN PARTS

MSZ-RW25VG
MSZ-RW35VG
MSZ-RW50VG

Part name	Check method and criterion	Figure				
Room temperature thermistor (RT11) Indoor coil thermistor (RT12, RT13)	Measure the resistance with a tester. Refer to 10-7. "Test point diagram and voltage", "Indoor electronic control P.C. board", for the chart of thermistor.					
Indoor fan motor (MF)	Check 10-6.④ "Check of indoor fan motor".					
Vane motor (MV1) (HORIZONTAL)	Measure the resistance between the terminals with a tester. (Temperature: 10 - 30°C)					
<table border="1"> <thead> <tr> <th>Color of the lead wire</th> <th>Normal</th> </tr> </thead> <tbody> <tr> <td>RED - YLW</td> <td>262 - 328 Ω</td> </tr> </tbody> </table>		Color of the lead wire	Normal	RED - YLW	262 - 328 Ω	
Color of the lead wire	Normal					
RED - YLW	262 - 328 Ω					
Vane motor (MV2) (VERTICAL)	Measure the resistance between the terminals with a tester. (Temperature: 10 - 30°C)					
<table border="1"> <thead> <tr> <th>Color of the lead wire</th> <th>Normal</th> </tr> </thead> <tbody> <tr> <td>RED - YLW</td> <td>219 - 273 Ω</td> </tr> </tbody> </table>		Color of the lead wire	Normal	RED - YLW	219 - 273 Ω	
Color of the lead wire	Normal					
RED - YLW	219 - 273 Ω					
i-see SENSOR MOTOR (MT)	Measure the resistance between the terminals with a tester. (Temperature: 10 - 30°C)					
<table border="1"> <thead> <tr> <th>Color of the lead wire</th> <th>Normal</th> </tr> </thead> <tbody> <tr> <td>RED - BRN</td> <td>262 - 328 Ω</td> </tr> </tbody> </table>		Color of the lead wire	Normal	RED - BRN	262 - 328 Ω	
Color of the lead wire	Normal					
RED - BRN	262 - 328 Ω					
AIR PURIFYING power	Check 10-6.⑥.					

10-6. TROUBLESHOOTING FLOW

A Check of indoor fan motor

The indoor fan motor error has occurred, and the indoor fan does not operate.

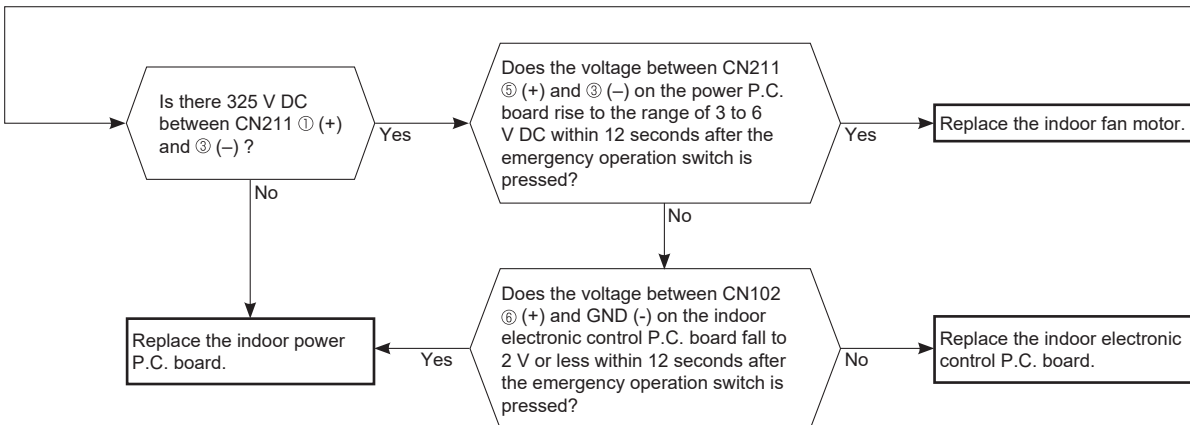
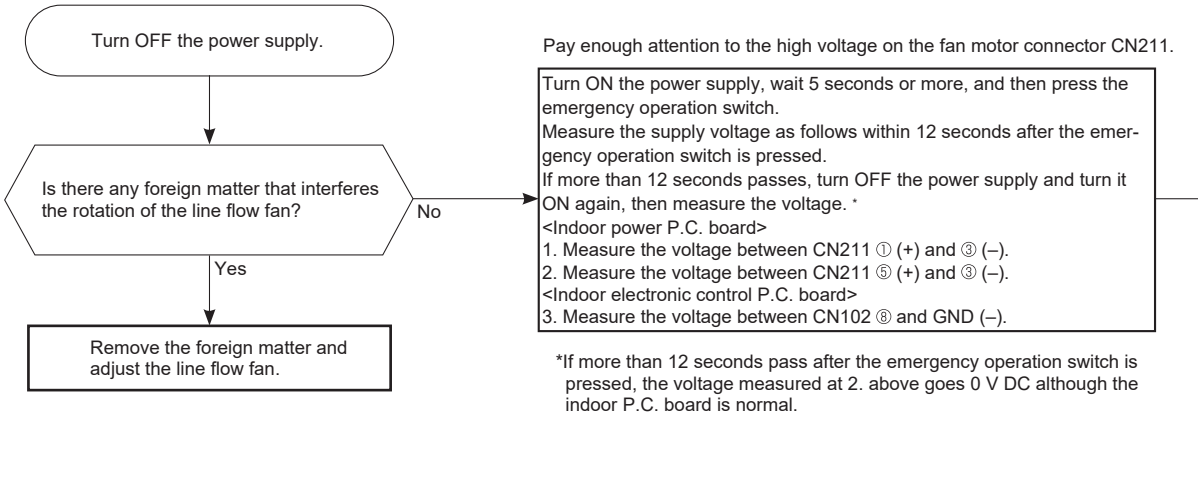

The indoor fan motor error has occurred, and the indoor fan repeats "12-second ON and 30-second OFF" 3 times, and then stops.

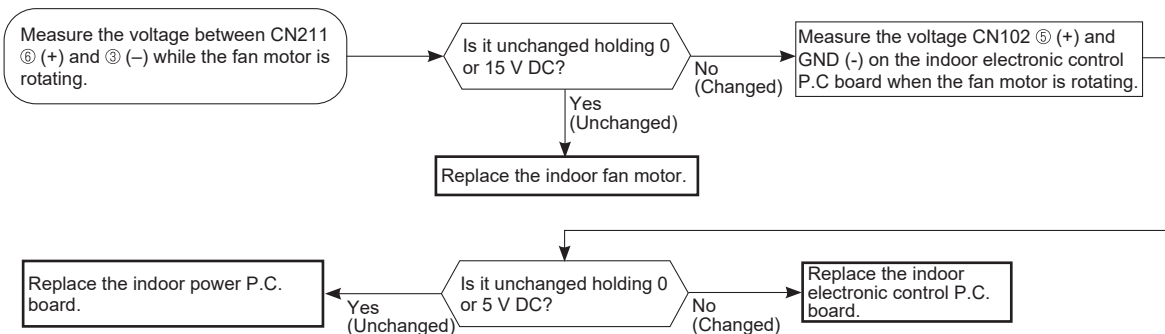

B Check of remote controller and indoor electronic control P.C. board

NOTE: Check if the remote controller is exclusive for this air conditioner.

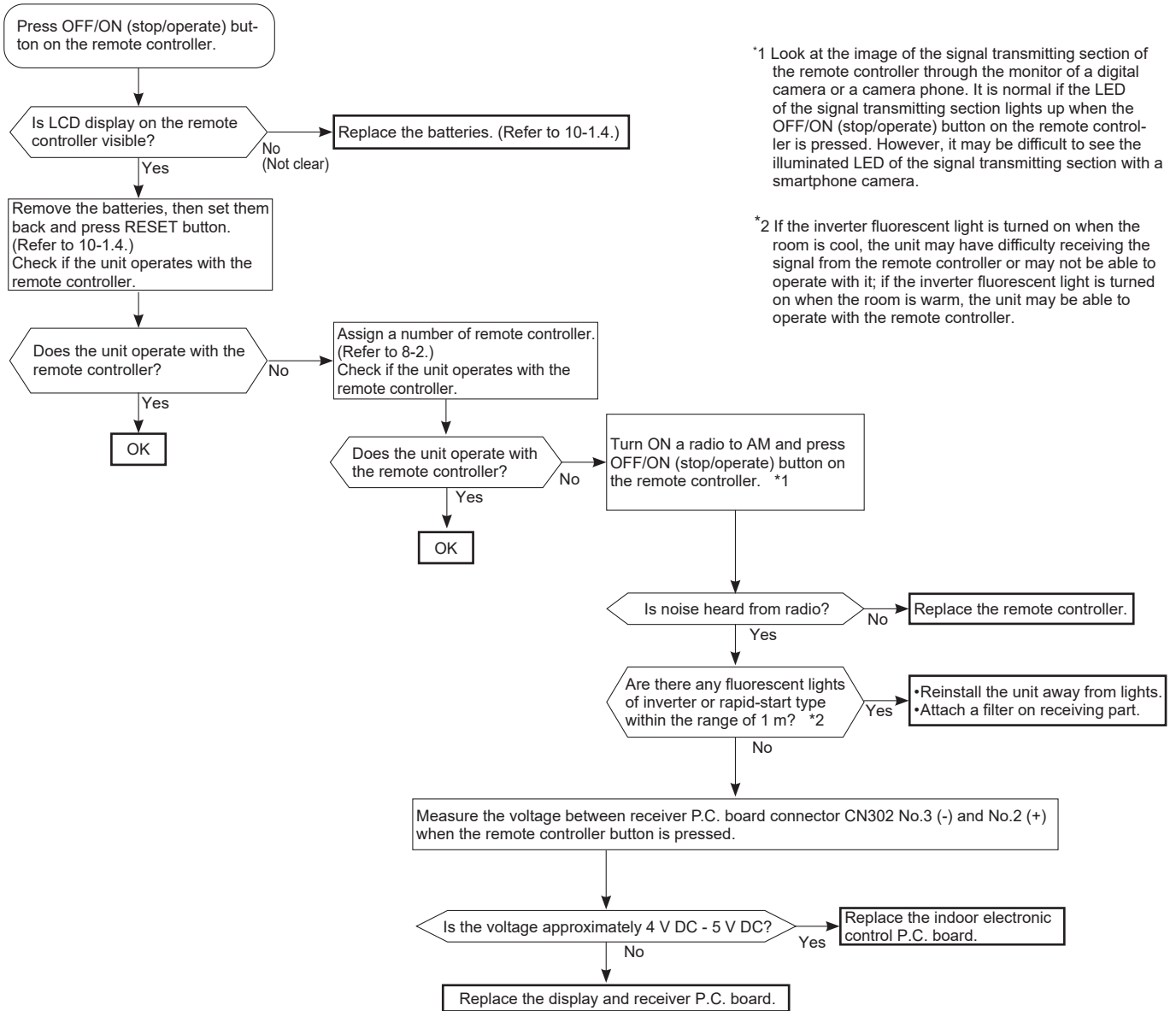

© Check of indoor P.C. board and indoor fan motor

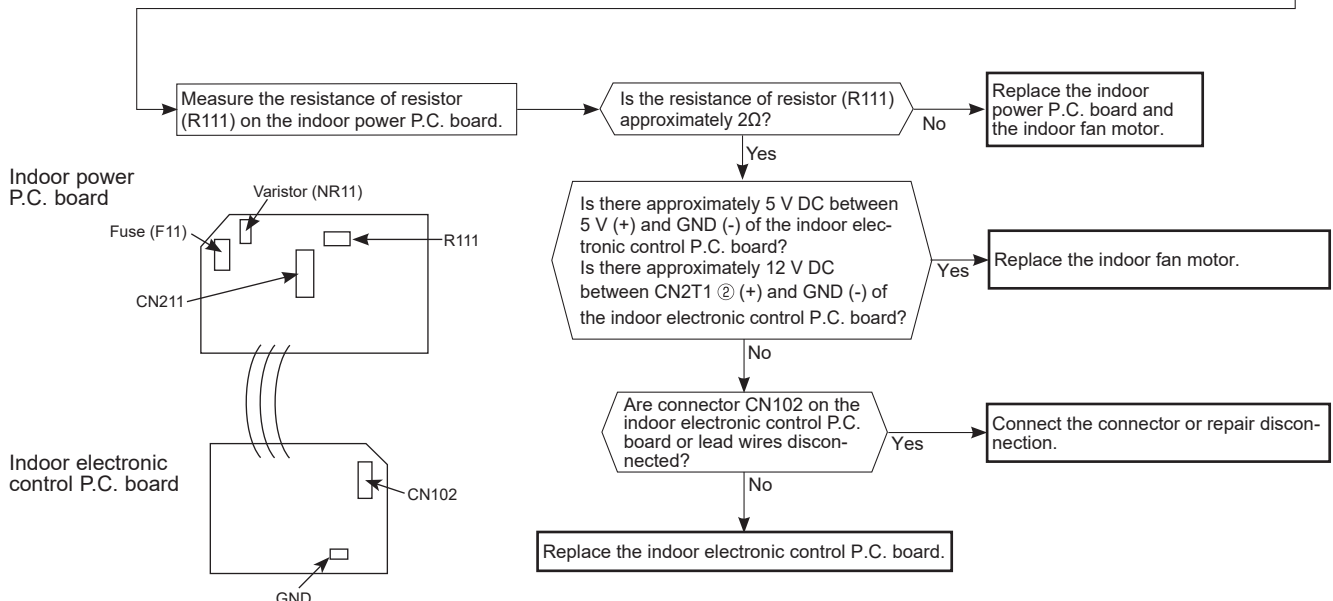
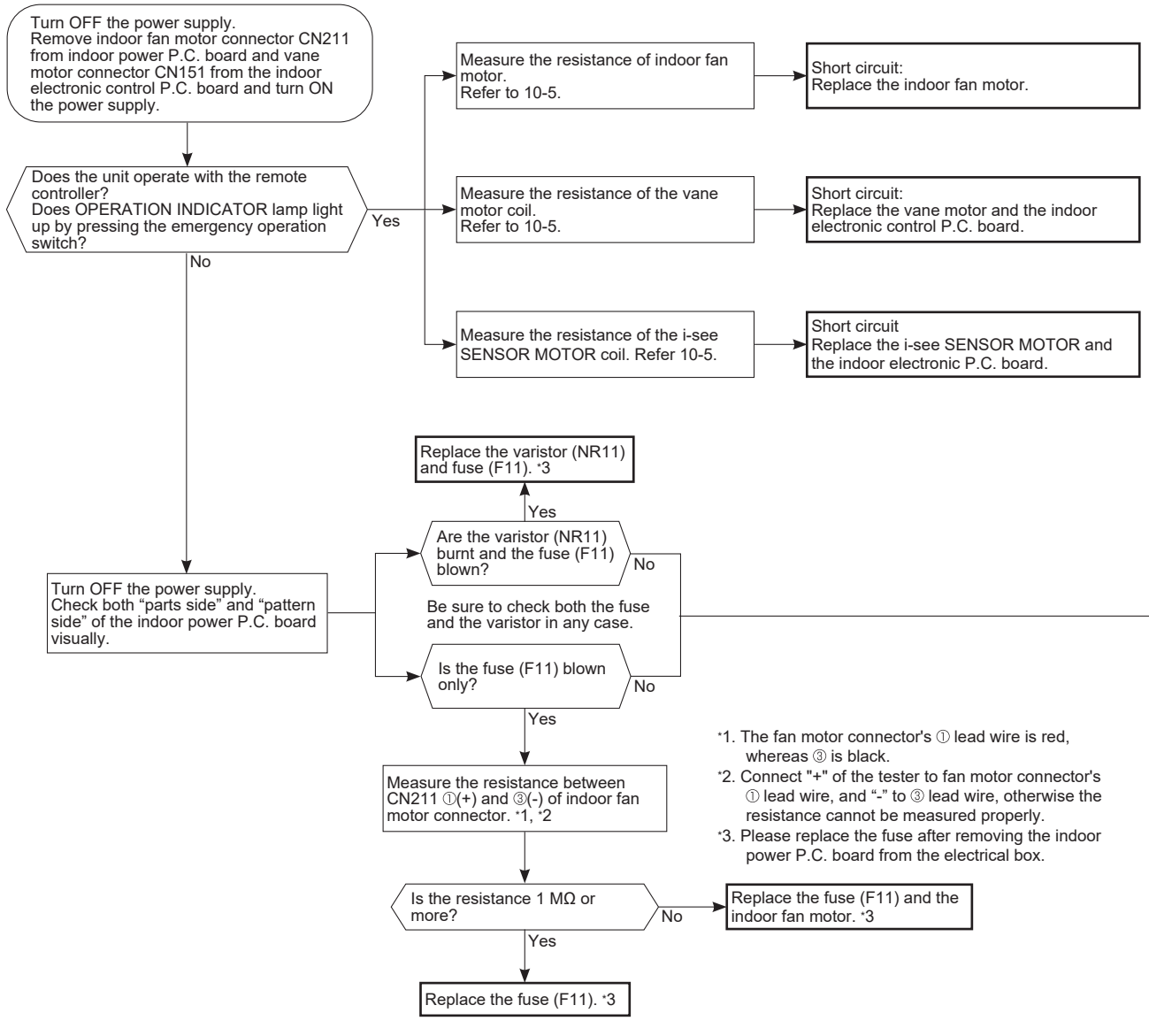

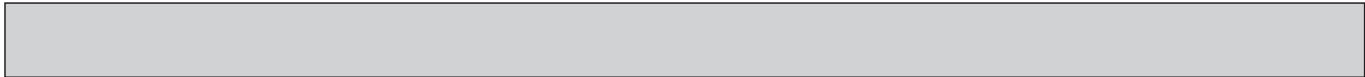

D How to check miswiring and serial signal error

MUZ Type

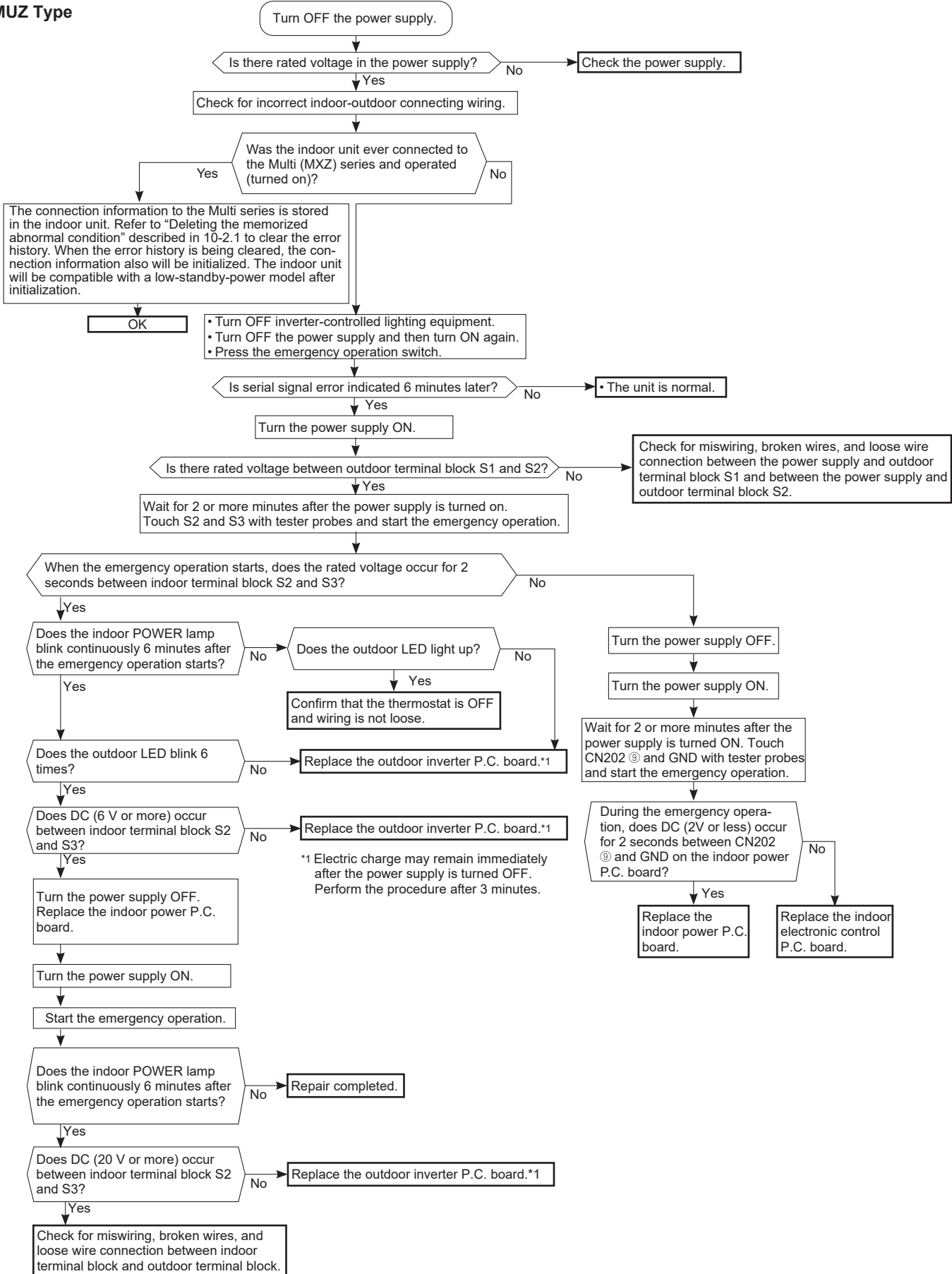

MXZ Type

LED indication

for communication status

Communication status is indicated by the LED.

Unit status

Blinking: Normal communication

Lit: Abnormal communication or not connected

Pattern 1 and 2 is repeatedly displayed alternately. Each pattern is displayed for 10 seconds.

NOTE: "Lit" in the table below does not indicate abnormal communication.

Outdoor control P.C. board

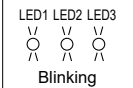

Pattern	LED 1	LED 2	LED 3
1	Unit A status	Unit B status	Lit
2	Unit C status	Unit D status	Not lit
3	Unit E status	—	Blinking

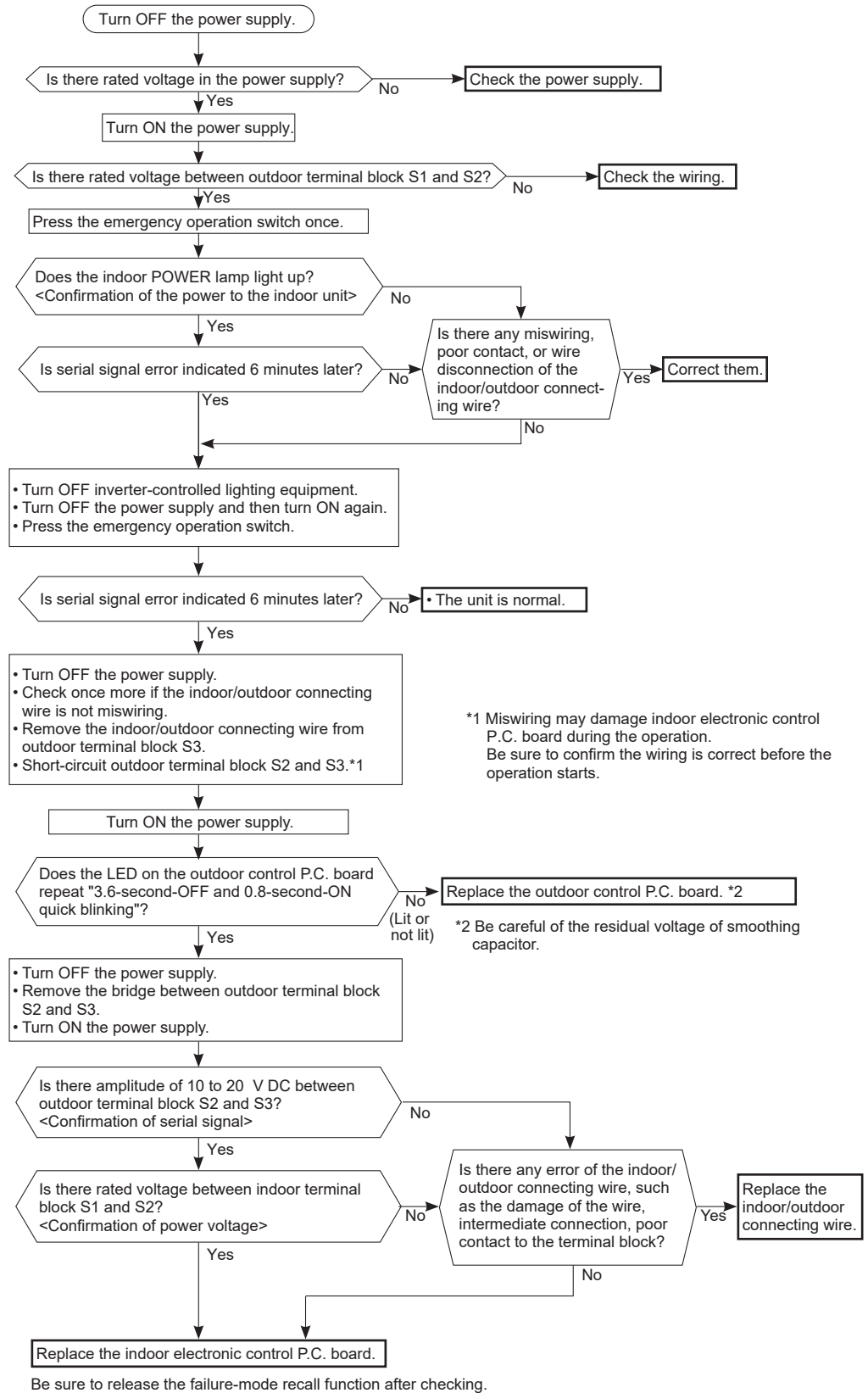

*1 Miswiring may damage indoor electronic control P.C. board during the operation. Be sure to confirm the wiring is correct before the operation starts.

*2 Be careful of the residual voltage of smoothing capacitor.

E Check of AIR PURIFYING power

After performing the check, make sure to release the failure mode recall function.

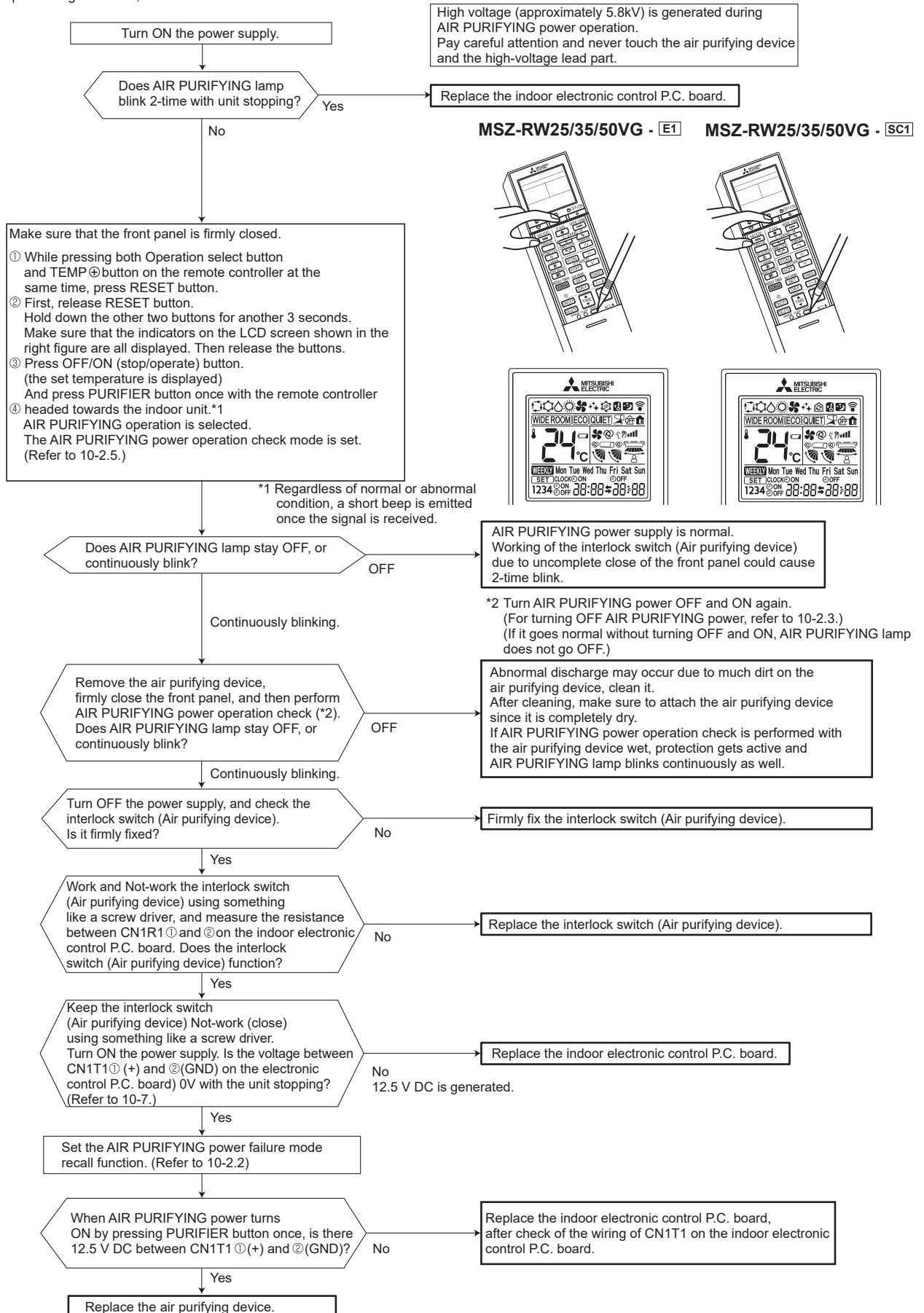

F Electromagnetic noise enters into TV sets or radios

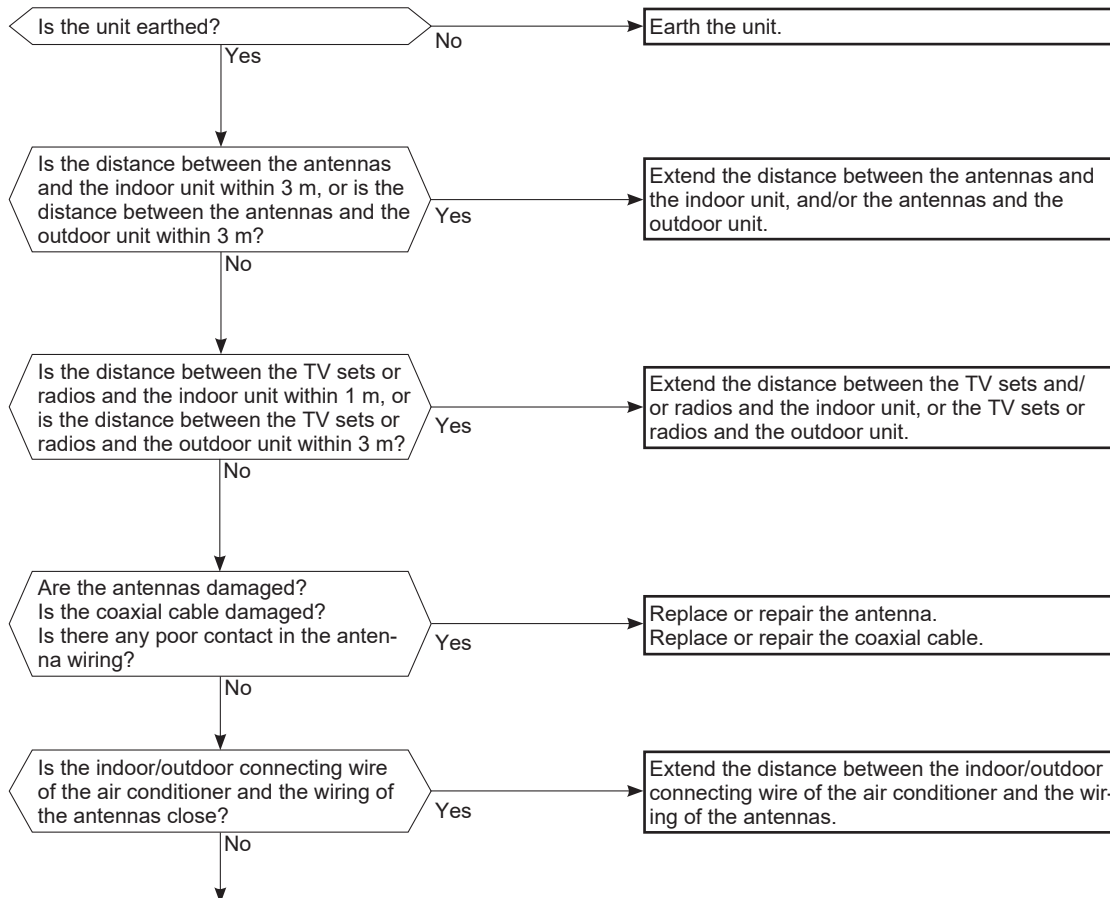

Even if all of the above conditions are fulfilled, the electromagnetic noise may enter, depending on the electric field strength or the installation condition (combination of specific conditions such as antennas or wiring).
Check the following before asking for service.

1. Devices affected by the electromagnetic noise
TV sets, radios (FM/AM broadcast, shortwave)
2. Channel, frequency, broadcast station affected by the electromagnetic noise
3. Channel, frequency, broadcast station unaffected by the electromagnetic noise
4. Layout of:
indoor/outdoor unit of the air conditioner, indoor/outdoor wiring, earth wire, antennas, wiring from antennas, receiver
5. Electric field intensity of the broadcast station affected by the electromagnetic noise
6. Presence or absence of amplifier such as booster
7. Operation condition of air conditioner when the electromagnetic noise enters in
 - 1) Turn OFF the power supply once, and then turn ON the power supply. In this situation, check for the electromagnetic noise.
 - 2) Within 3 minutes after turning ON the power supply, press OFF/ON (stop/operate) button on the remote controller for power ON, and check for the electromagnetic noise.
 - 3) After a short time (3 minutes later after turning ON), the outdoor unit starts running. During operation, check for the electromagnetic noise.
 - 4) Press OFF/ON (stop/operate) button on the remote controller for power OFF, when the outdoor unit stops but the indoor/outdoor communication still runs on. In this situation, check for the electromagnetic noise.

10-7. TEST POINT DIAGRAM AND VOLTAGE

Indoor power P.C. board, Indoor electronic control P.C. board, Display and receiver P.C. board, Switch buzzer P.C. board

MSZ-RW25VG MSZ-RW35VG MSZ-RW50VG

Indoor power P.C. board

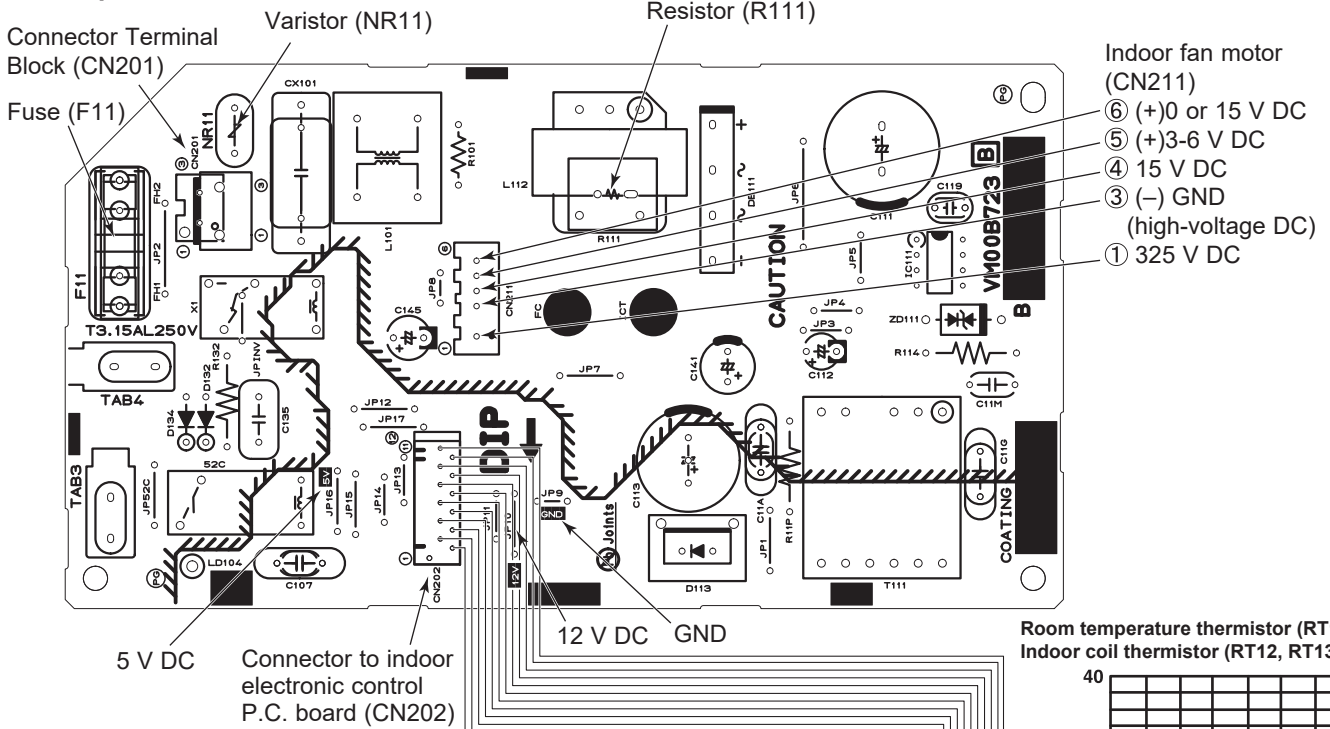

Indoor electronic control P.C. board

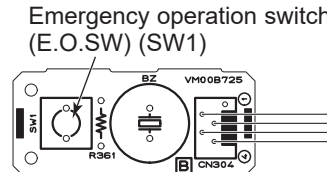
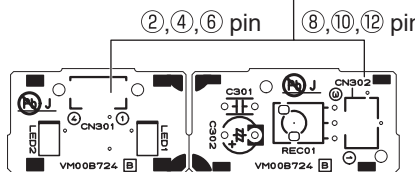
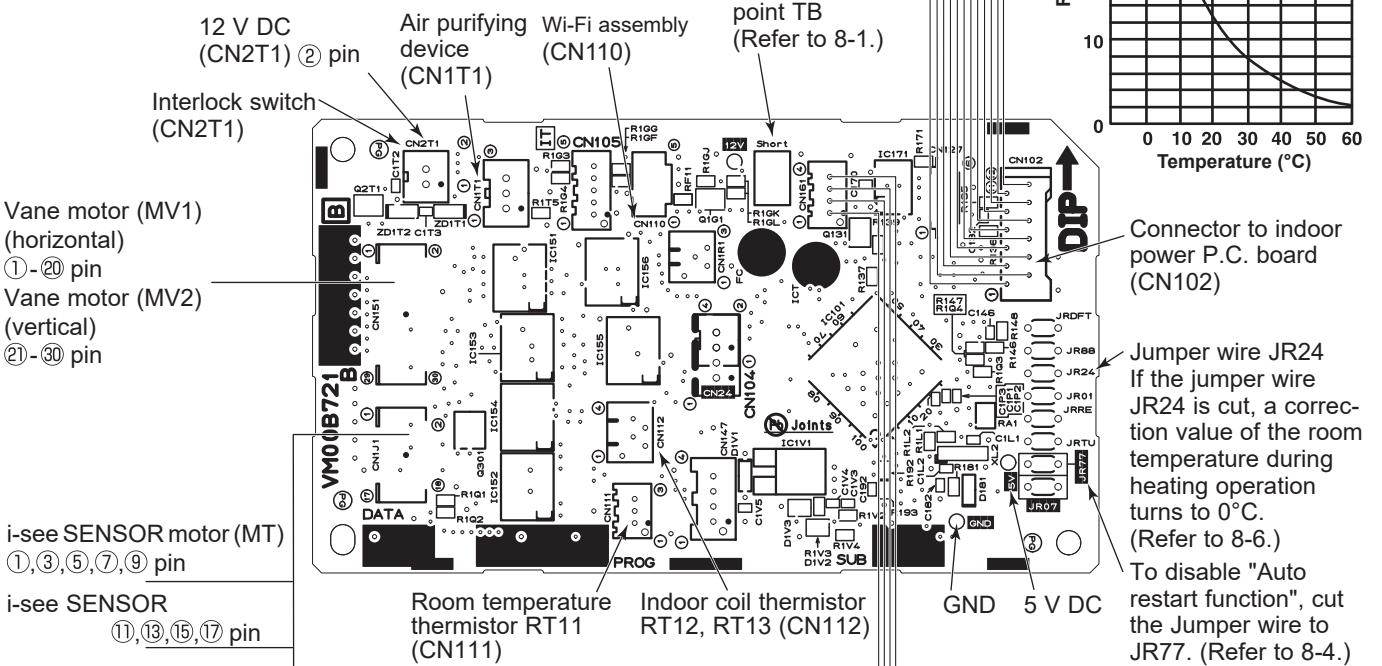

<Detaching method of the terminal with locking mechanism>

The terminal which has the locking mechanism can be detached as shown below.

There are 2 types of the terminal with locking mechanism.

The terminal without locking mechanism can be detached by pulling it out.

Check the shape of the terminal before detaching.

(1) Slide the sleeve and check if there is a locking lever or not.

(2) The terminal with this connector shown below has the locking mechanism.

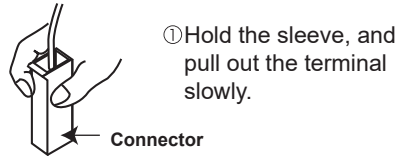
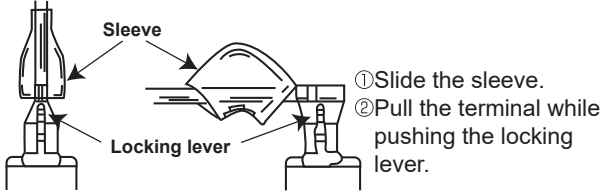

MSZ-RW25VG MSZ-RW35VG MSZ-RW50VG

NOTE: Turn OFF the power supply before disassembly.

→ : Indicates the visible parts in the photos/figures.
 ---→ : Indicates the invisible parts in the photos/figures.

OPERATING PROCEDURE	PHOTOS/FIGURES
<p>1. Removing the front panel and the panels (U/R/L/ F) and horizontal vanes (upper R/L), (lower R/L) Removing the front panel (Photos 1, 2) (1) Lift the front panel until a "click" is heard. (2) Hold the hinges and pull to remove the front panel.</p> <p>Removing the horizontal vanes (upper R/L), (lower R/L)(Photos 3) (1) Unlock the rocks of the horizontal vane upper (R)(2 points). Pull and remove the horizontal vane upper (R) to the side. (2) Remove the horizontal vane upper (L) and horizontal vane lower (R) (L) by the same procedure.</p>	<p>Photo 1</p> <p>Photo 2</p> <p>Photo 3</p>

OPERATING PROCEDURE

How to install the front panel (Photos 1, 2)

- (1) Attach the horizontal vanes (upper R/L) and (lower R/L)
- (2) Install the front panel to the indoor unit.
- (3) Push the locations indicated by the arrows firmly to close the front panel (Figure 1).

Removing the panel (U) (Photo 1)

- (1) Remove the front panel.
- (2) Remove the horizontal vanes (upper R/L), (lower R/L), and the right and left corner boxes.
- (3) Remove the 2 screw caps on the right and left sides of the panel (U), and remove the 2 screws.
- (4) Disengage the catch on the center of the panel (U), and pull it toward you to remove.

How to install the panel (U) (Photo 1)

- (1) Press the center of the panel (U) from the front to snap into place.
- (2) Install the 2 screws in the right and left sides of the panel (U), and cover them with 2 screw caps.

Removing the panel (R) (Photos 1,2,3,4)

- (1) Remove the front panel, the horizontal vanes (upper R/L), (lower R/L), and the corner boxes (R) (L).
- (2) Remove the panel (U).
- (3) Remove the 3 screws of the panel (R), and pull the top of the panel (R) toward you to remove.

How to install the panel (R) (Photo 4)

- (1) Install the panel (R) from the bottom to the top.
- (2) Install the 3 screws in the panel (R).

Removing the panel (L) (Photos 1,2,3,4)

- (1) Remove the front panel, the horizontal vanes (upper R/L), (lower R/L), and the corner boxes (R) (L).
- (2) Remove the panel (U).
- (3) Remove the screw of the panel (L), and pull the top of the panel (L) toward you to remove.

How to install the panel (L) (Photo 4)

- (1) Install the panel (L) from the bottom to the top.
- (2) Install the screw in the panel (L).

Removing the panel (F) (Photo 4)

- (1) Remove the front panel, the horizontal vanes (upper R/L), (lower R/L), and the corner boxes (R) (L).
- (2) Remove the panels (U) (R) (L).
- (3) Remove the Wi-Fi assembly on the right side of the panel (F). Pull out its cable (Refer to section 5).
- (4) Remove the panel (F) from the bottom to the top.

How to install the panel (F)

- (1) Install the panel (F) from the top to the bottom.
- (2) Install the Wi-Fi assembly.

PHOTOS/FIGURES

Figure 1

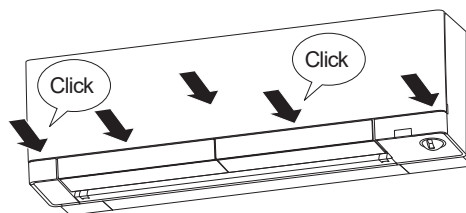
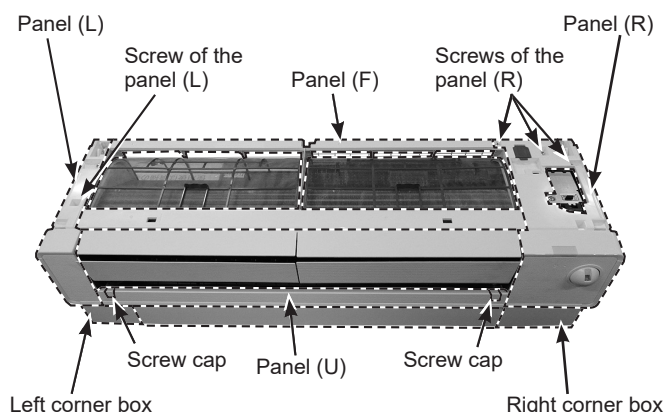

Photo 4



OPERATING PROCEDURE

PHOTOS/FIGURES

2. Removing the indoor electrical box (Photos 5, 6, 7, 8)

- (1) Remove the front panel, the horizontal vanes (upper R/L), (lower R/L), the corner boxes (R) (L), and the panels (U) (R) (L) (refer to section 1).
- (2) Remove the earth wire.
- (3) Remove the screw of the V.A. clamp, and remove the V.A. clamp (Photo 5).
- (4) Remove the screw of the electrical cover, and remove the electrical cover (Photo 6).
- (5) Disconnect the following connectors (Photo 8):
<Indoor electronic control P.C. board>
CN1J1 (DISPLAY AND i-see SENSOR ASSEMBLY)
- (6) Remove the DISPLAY AND i-see SENSOR ASSEMBLY (Photo 7).
- (7) Disconnect the following connector (Photo 8):
<Indoor electronic control P.C. board>
CN110 (Wi-Fi assembly)
CN2T1 [Interlock switch (Air purifying device)]
CN161 (Switch buzzer P.C. board)
CN211 (Indoor fan motor)
CN151 (Vane motors)
CN112 (Indoor coil thermistor)
CN1T1 (Air purifying device)
- (8) Remove the electrical box.

Photo 5

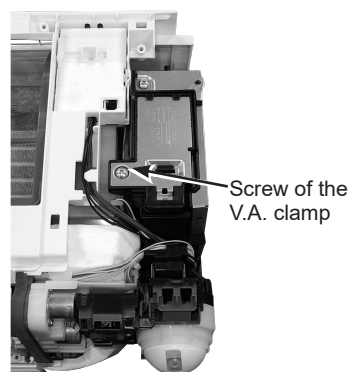

Photo 6

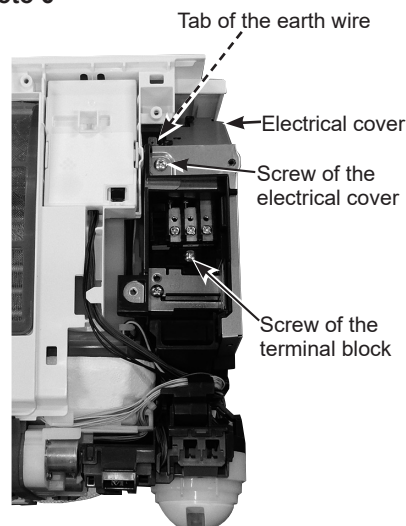
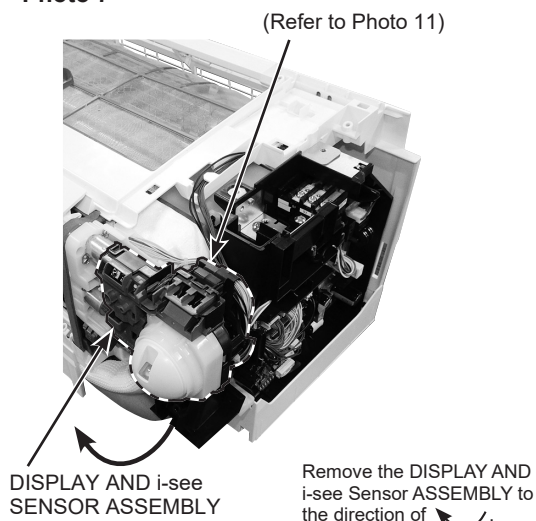

Photo 7



OPERATING PROCEDURE

3. Removing the indoor electronic control P.C. board, the indoor power P.C. board, the indoor terminal block, and the room temperature thermistor

(1) Remove the electrical box (Refer to section 2).

Removing the indoor terminal block (Photos 6, 8)

- (2) Remove the screw of the terminal block. (Photo 6)
- (3) Disconnect the connectors of the indoor terminal block (TAB3 and CN201).

Removing the indoor electronic control P.C. board and the indoor power P.C. board (Photo 8)

- (2) Disconnect all the connectors on the indoor electronic control P.C. board and the indoor power P.C. board.
- (3) Remove the indoor electronic control P.C. board and the indoor power P.C. board.

Removing the room temperature thermistor (Photo 8)

- (2) Disconnect the following connector:
CN111 (Room temperature thermistor)
- (3) Remove the room temperature thermistor.

PHOTOS/FIGURES

Photo 8 (Enlarged view of the indoor electronic control P.C. board)

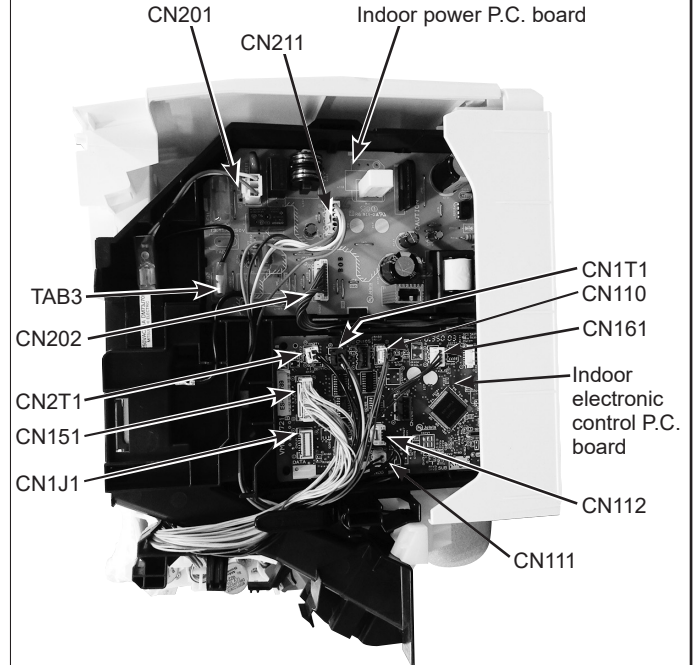

OPERATING PROCEDURE

PHOTOS/FIGURES

4. Removing the DISPLAY AND i-see SENSOR ASSEMBLY, the display P.C. board, and the receiver P.C. board (Photo 9).

- (1) Remove the DISPLAY AND i-see SENSOR ASSEMBLY (Refer to section 2).
- (2) Cut off the cable tie of the lead wires of the DISPLAY AND i-see SENSOR ASSEMBLY at the back side of the display cover (Photo 9-2).
- (3) Remove the lead wires of the DISPLAY AND i-see SENSOR ASSEMBLY from the hooks (Photo 9-2).
- (4) Disengage the 2 catches of the display cover, and remove the display cover (Photo 9-1,2).
- (5) Remove the display and receiver P.C. board (Photo 9-3).

Photo 9 (Details of the display, DISPLAY AND i-see SENSOR ASSEMBLY, and board in the display cover)

Photo 9-1

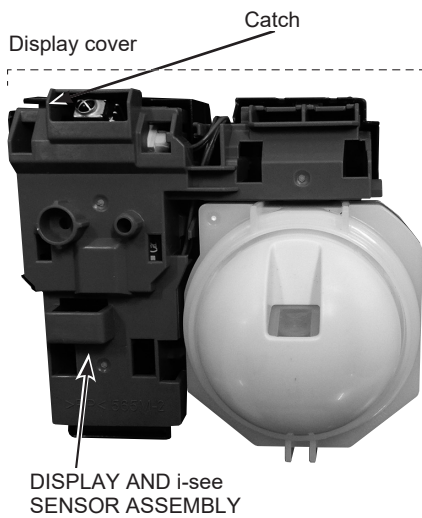

Front view of DISPLAY AND i-see SENSOR ASSEMBLY

Photo 9-2

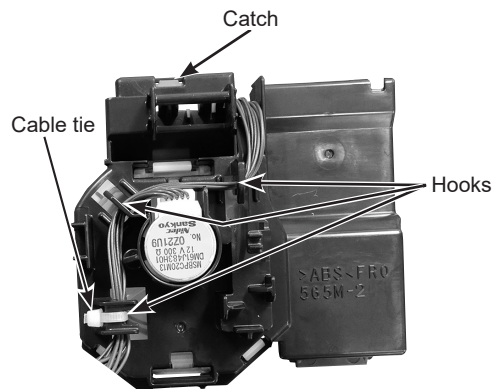

Back side view of DISPLAY AND i-see SENSOR ASSEMBLY

Photo 9-3

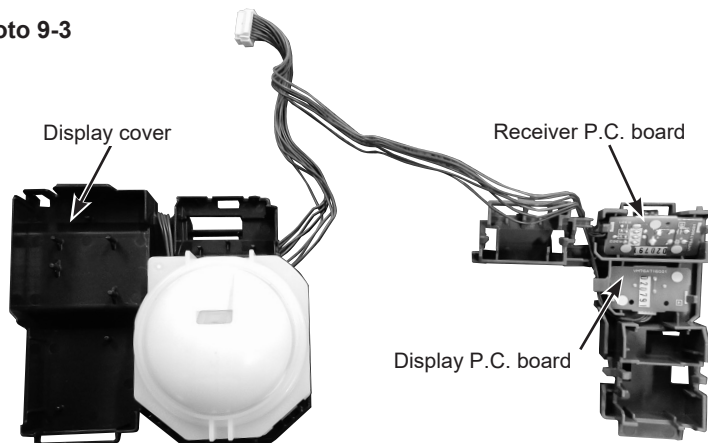

Exploded view of display cover and DISPLAY AND i-see SENSOR ASSEMBLY (Display P.C. board, receiver P.C. board)

OPERATING PROCEDURE

5. Removing the Wi-Fi assembly (Photos 3,10)

- (1) Remove the front panel, horizontal vanes (upper R/L), (lower R/L), corner boxes (R) (L), and the panels (U) (R) (L).
- (2) Remove the screw of the V.A. clamp and remove the V.A. clamp. (Photo 5)
- (3) Remove the screw of the electrical cover, and remove the electrical cover.
- (4) Disconnect the following connector (Photo 8):
<Indoor electronic control P.C. board>
CN110 (Wi-Fi assembly)
CN2T1 [Interlock switch (Air purifying device)]
CN161 (Switch buzzer P.C. board)
- (5) Remove the cable of Wi-Fi assembly from the PANEL(F).
- (6) Disengage the catch and remove the Wi-Fi assembly.

How to install the Wi-Fi assembly (Photo 10,11)

- (1) Install the panel (F).
- (2) Attach the Wi-Fi assembly.
- (3) Hook the cable of Wi-Fi assembly to the PANEL(F).
- (4) Connect the connector of CN110 (Wi-Fi assembly), CN2T1 [Interlock switch (Air purifying device)] and CN161 (Switch buzzer P.C. board) to the indoor electronic control P.C. board.
- (5) Install the electrical cover, and install the screw in the electrical cover.
- (6) Install the V.A. clamp, and install the screw in the V.A. clamp.
- (7) Install the panel (R) (L) (U).
- (8) Install the corner boxes (R) (L), and horizontal vanes (upper R/L), (lower R/L).
- (9) Install the front panel.

PHOTOS/FIGURES

Photo 10

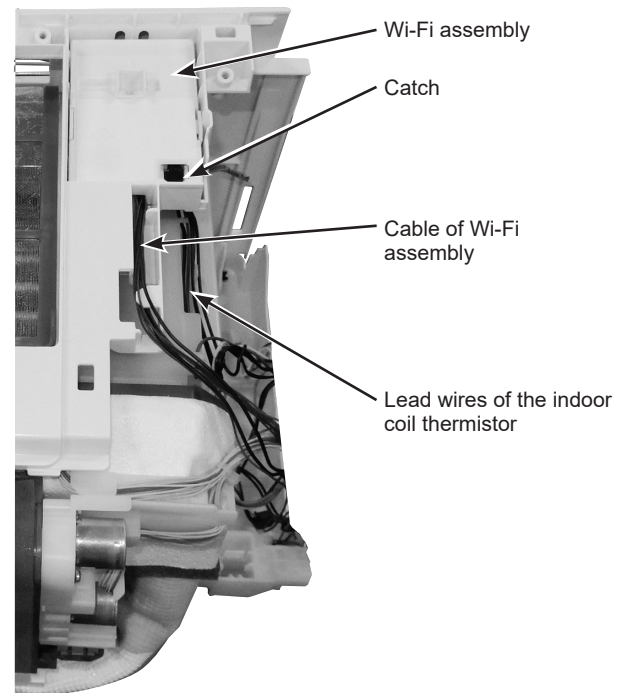
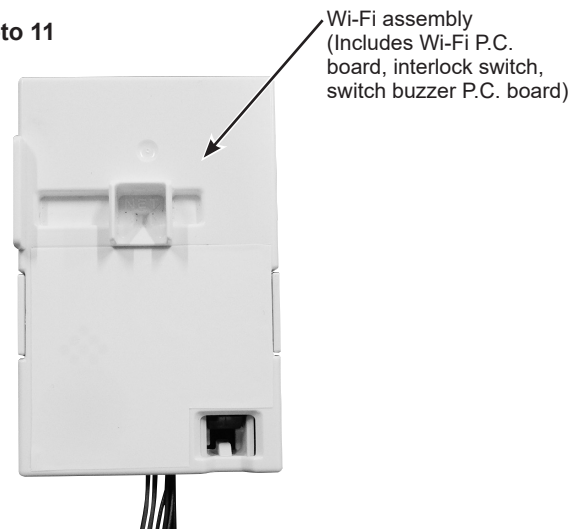

Photo 11



OPERATING PROCEDURE

6. Removing the horizontal vanes (R)(L) and the horizontal vane motors (R)(L) (Photos 8, 12, 13, 14)

- (1) Remove the front panel, horizontal vanes (upper R/L), (lower R/L), the corner boxes (R) (L), the panels (U) (R) (L), V.A. clamp, the electrical cover, Wi-Fi assembly, the panel (F), and DISPLAY and i-see SENSOR ASSEMBLY.
- (2) Remove the following connector (Photo 8):
<Indoor electronic control P.C. board>
CN151 (Vane motors)
- (3) Pull out the drain hose from the nozzle assembly.
- (4) Pull and remove the nozzle assembly (4 catches)
(Photo 12).
- (5) Cut off the cable tie to secure the lead wires on the right side of the nozzle assembly (Photo 13).

Removing horizontal vane motors (R) (Photo 13)

- (6) Loosen the lead wires, and disconnect the connector of the horizontal vane motors (R).
- (7) Remove the 2 screws of the horizontal vane motors (R).
- (8) Remove the horizontal vane motors (R).

Removing horizontal vane motors (L) (Photo 14)

- (9) Loosen the lead wires, and disconnect the connector of the horizontal vane motors (L).
- (10) Remove the 2 screws of the horizontal vane motors (L).
- (11) Remove the horizontal vane motors (L).

PHOTOS/FIGURES

Photo 12

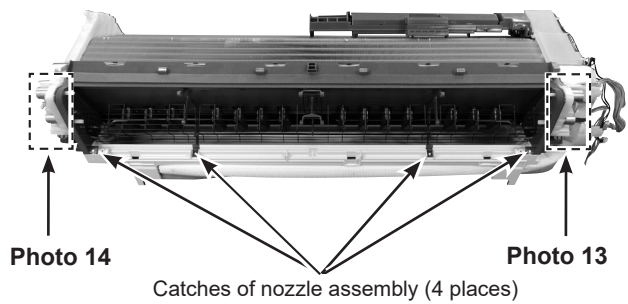

Photo 13

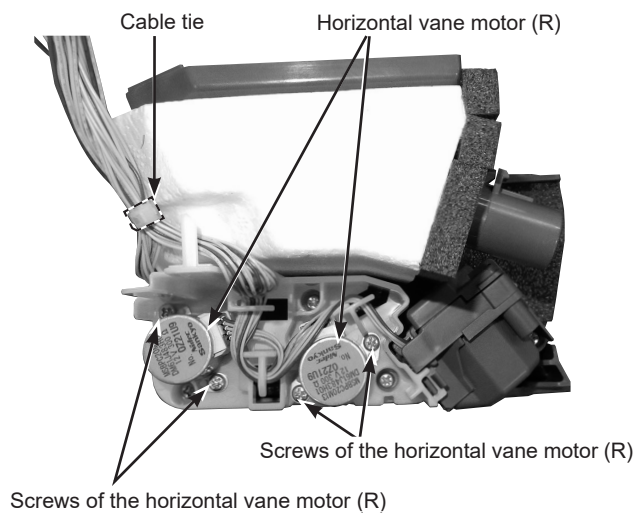
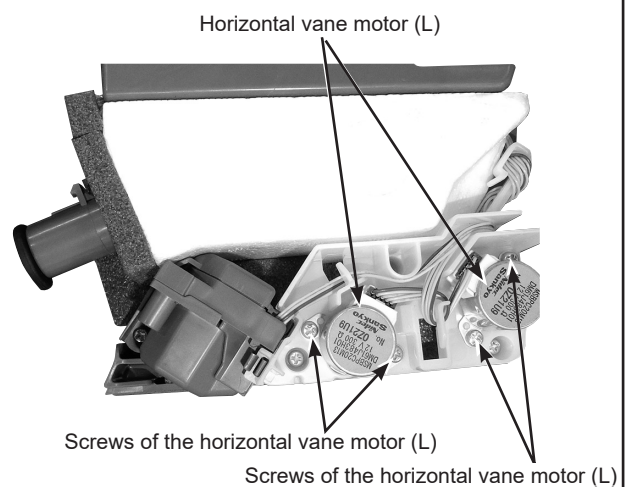

Photo 14



OPERATING PROCEDURE

7. Removing the vertical vane motor units (R) (L) and the vertical vane motors (R) (L)

- (1) Remove the front panel, horizontal vanes (upper R/L) (lower R/L), the corner boxes (R) (L), the panels (U) (R) (L), V.A. clamp, the electrical cover, Wi-Fi assembly, the panel (F), and DISPLAY and i-see SENSOR ASSEMBLY.
- (2) Remove the following connector (Photo 8):
<Indoor electronic control P.C. board>
CN151 (Vane motors)
- (3) Pull out the drain hose from the nozzle assembly. Pull and remove the nozzle assembly (4 catches) (Photo 12).
- (4) Cut off the cable tie to secure the lead wires on the right side of the nozzle assembly (Photo 15).

Removing the horizontal vane motor unit (R) and the vertical vane motor (R) (Photo 15,16)

- (5) Remove the 3 screws of the horizontal motor unit (R) indicated in (Photo15), and remove the lead wires of the vane motors (R).
- (6) Disengage the catch of the horizontal vane motor unit (R), and remove the horizontal vane motor unit (R) (Photo15).
- (7) Disengage the link of the vertical vane motor unit (R).
- (8) Disengage the catch of the vertical vane motor unit (R), and remove the vertical vane motor (R) from the vertical vane motor unit (R), (Photo16-1).

PHOTOS/FIGURES

Photo 15

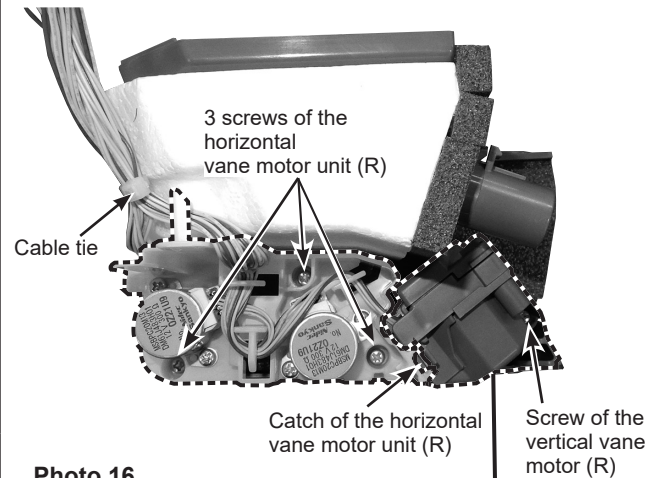

Photo 16

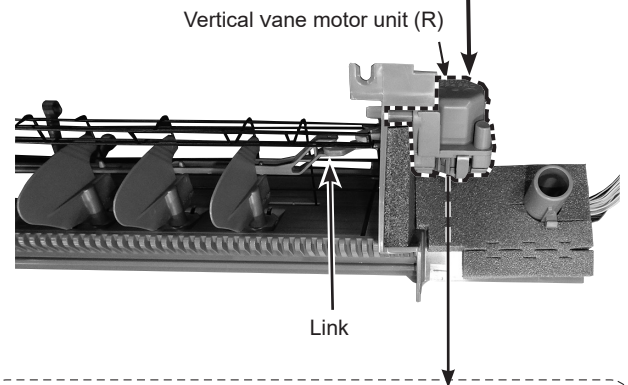
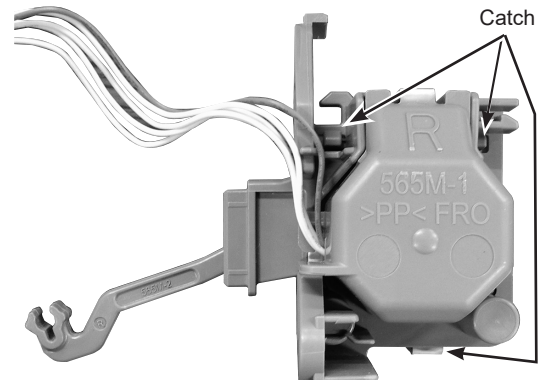

Photo 16-1



OPERATING PROCEDURE

Removing the horizontal vane motor unit (L) and the vane motor (L) (vertical) (Photo 17, 18)

- (9) Remove the 3 screws of the horizontal motor unit (L) indicated in (Photo 17).
- (10) Disengage the catch of the horizontal vane motor unit (L), and remove the horizontal vane motor unit (L). (Photo17)
- (11) Disengage the link of the vertical vane motor unit (L) (Photo18-1).
- (12) Disengage the catch of the vertical vane motor unit (L), and remove the vertical vane motor (L) from the vertical vane motor unit (L), (Photo18-1).

Photo 17

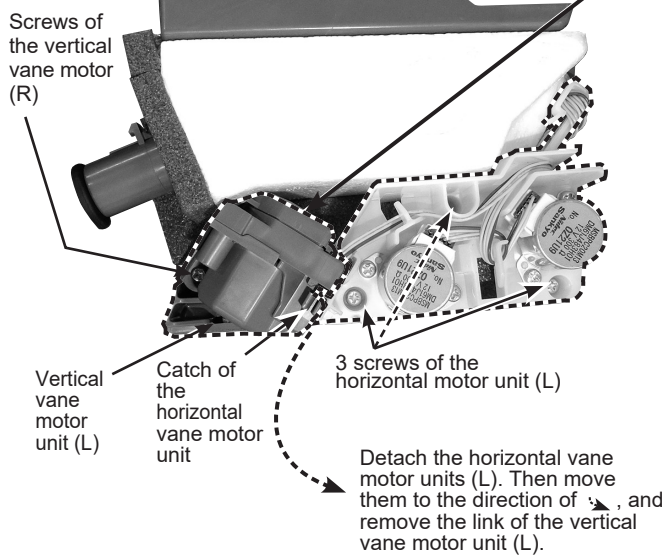

PHOTOS/FIGURES

Photo 18

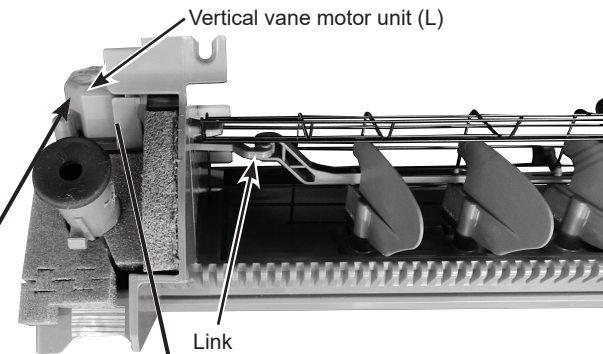

Photo 18-1

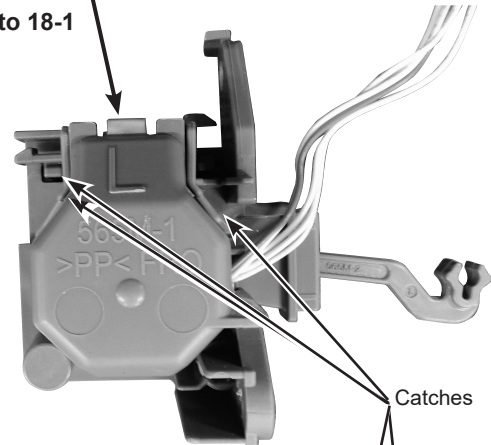
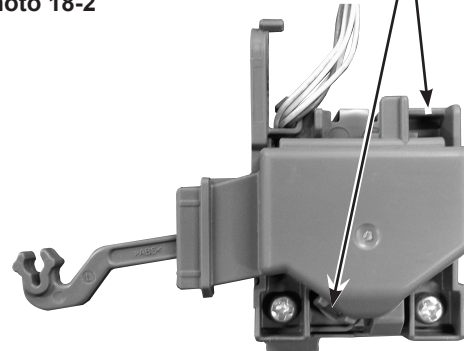

Photo 18-2



OPERATING PROCEDURE

8. Removing the air purifying device (Photo 19)

- (1) Remove the front panel, the horizontal vanes (upper R/L), (lower R/L), the corner boxes (R) (L), the panels (U) (R) (L), V.A. clamp, the electrical cover, Wi-Fi assembly, and the panel (F).
- (2) Disconnect the following connector (Photo 8):
<Indoor electronic control P.C. board>
CN1T1 (Air purifying device)
- (3) Remove the lead wires from the water cover.
- (4) Remove the screw of the air purifying device support.
(Photo 21)
- (5) Remove the air purifying device support.

9. Removing the line flow fan, the indoor fan motor assembly, the indoor coil thermistor, and the heat exchanger (Photo 19, 20, 21, 22, 23)

- (1) Remove the front panel, the horizontal vanes (upper R/L), (lower R/L), the corner boxes (R) (L), the panels (U) (R) (L), Wi-Fi assembly, the panel (F), the electrical box, the nozzle assembly and the air purifying device.
- (2) Loosen the screw inside the right side of the line flow fan (Photo 20).
- (3) Remove the 3 screws of the fan motor assembly. Pull the fan motor assembly slightly toward you, and remove it by pulling to the right (Photo 21).
- (4) Remove the indoor coil thermistor from the heat exchanger.
- (5) Remove the 2 screws of the hairpin holder on the left side of the heat exchanger. Raise the left side of the heat exchanger, and pull the line flow fan to the lower left to remove (Photo 22).
- (6) Disengage the 2 catches on the right side of the heat exchanger, and remove the heat exchanger (Photo 23).
* When attaching the line flow fan, screw the line flow fan so 4 mm gap is provided between the right end of the line flow fan and the right wall of the air passage of the box (Figure 2).

Figure 2

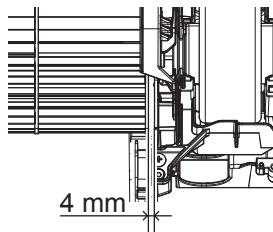

Photo 22

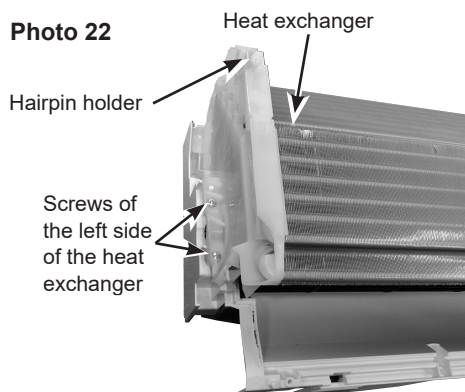
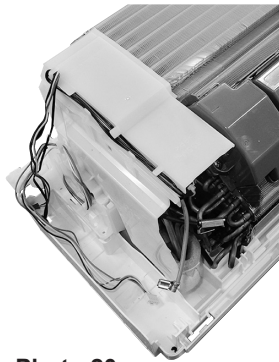

Photo 19



NOTE:

Install the fan motor and lead wires in the former position when assembling the fan motor.
(Photo19)

Photo 20

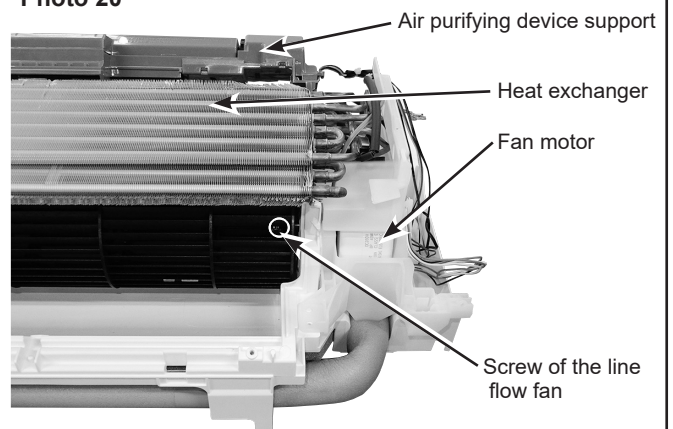

Photo 21

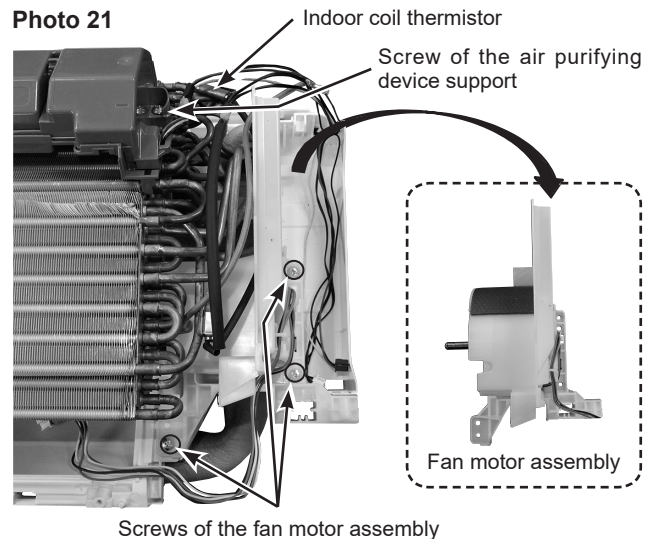
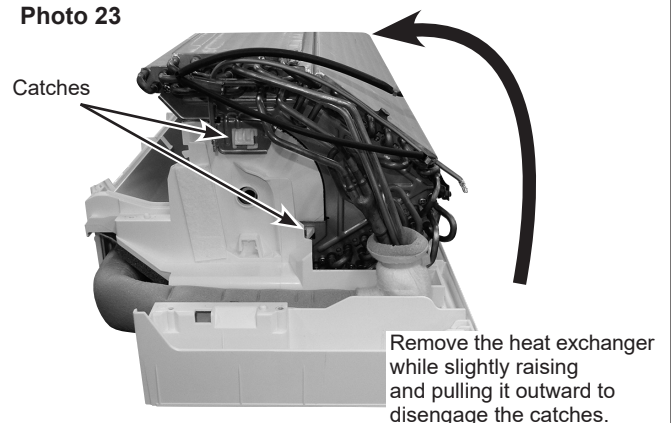

Photo 23



Fixing the indoor coil thermistor

*There are 2 forms of parts for fixing the indoor coil thermistor.

Clip shape



Holder shape

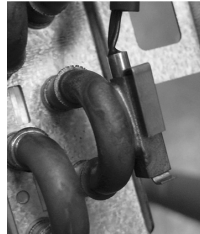

When fixing the indoor coil thermistor to the clip-shape/holder-shape part, the lead wire should point down.

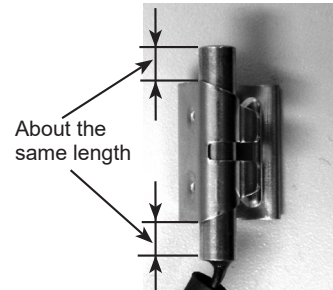

Position and procedure for mounting the clip-shape part

1. Set the indoor coil thermistor in the center of the clip-shape part.



2. Check the (marked) mounting position.



3. Mount the clip-shape part.



NOTE:

- Take care to avoid loss and accidental falling of the clip-shape part inside the unit.
- Mount the clip-shape part on the marked position.
- Do not pull the lead wire when removing the indoor coil thermistor.

MITSUBISHI ELECTRIC CORPORATION

HEAD OFFICE: TOKYO BUILDING, 2-7-3, MARUNOUCHI, CHIYODA-KU, TOKYO 100-8310, JAPAN