

Air-Conditioners For Building Application INDOOR/OUTDOOR UNIT



CMH-WM250V-A, CMH-WM350V-A, CMH-WM500V-A

INSTALLATION MANUAL

For safe and correct use, please read this installation manual thoroughly before installing the air-conditioner unit.

INSTALLATIONSHANDBUCH

Zum sicheren und ordnungsgemäßen Gebrauch der Klimageräte das Installationshandbuch gründlich durchlesen.

MANUEL D'INSTALLATION

Veuillez lire le manuel d'installation en entier avant d'installer ce climatiseur pour éviter tout accident et vous assurer d'une utilisation correcte.

INSTALLATIEHANDLEIDING

Voor een veilig en juist gebruik moet u deze installatiehandleiding grondig doorlezen voordat u de airconditioner installeert.

MANUAL DE INSTALACIÓN

Para un uso seguro y correcto, lea detalladamente este manual de instalación antes de montar la unidad de aire acondicionado.

MANUALE DI INSTALLAZIONE

Per un uso sicuro e corretto, leggere attentamente questo manuale di installazione prima di installare il condizionatore d'aria.

ΕΓΧΕΙΡΙΔΙΟ ΟΔΗΓΙΩΝ ΕΓΚΑΤΑΣΤΑΣΗΣ

Για ασφάλεια και σωστή χρήση, παρακαλείστε διαβάσετε προσεκτικά αυτό το εγχειρίδιο εγκατάστασης πριν αρχίσετε την εγκατάσταση της μονάδας κλιματισμού.

MANUAL DE INSTALAÇÃO

Para segurança e utilização correctas, leia atentamente este manual de instalação antes de instalar a unidade de ar condicionado.

INSTALLATIONSMANUAL

Læs venligst denne installationsmanual grundigt, før De installerer aircondition anlægget, af hensyn til sikker og korrekt anvendelse.

INSTALLATIONSHANDBOK

Läs den här installationshandboken noga innan luftkonditioneringsenheten installeras, för säker och korrekt användning.

MONTAJ ELKİTABI

Emniyetli ve doğru biçimde nasıl kullanılacağını öğrenmek için lütfen klima cihazını monte etmeden önce bu elkitabını dikkatle okuyunuz.

РЪКОВОДСТВО ЗА МОНТАЖ

За безопасна и правилна употреба, моля, прочетете внимателно това ръководство преди монтажа на климатизатора.

PODRECZNIK INSTALACJI

W celu bezpiecznego i poprawnego korzystania należy przed zainstalowaniem klimatyzatora dokładnie zapoznać się z niniejszym podręcznikiem instalacji.

INSTALLASJONSHÅNDBOK

For sikker og riktig bruk, skal du lese denne installasjonshåndboken nøye før du installerer klimaanlegget.

РУКОВОДСТВО ПО УСТАНОВКЕ

Для осторожного и правильного использования прибора необходимо тщательно ознакомиться с данным руководством по установке до выполнения установки кондиционера.

PRIRUČKA K INSTALACI

V zájmu bezpečného a správného používání si před instalací klimatizační jednotky důkladně pročtěte tuto příručku k instalaci.

NÁVOD NA INŠTALÁCIU

Pre bezpečné a správne použitie si pred inštalovaním klimatizačnej jednotky, prosím, starostlivo prečítajte tento návod na inštaláciu.

TELEPÍTÉSI KÉZIKÖNYV

A biztonságos és helyes használatához, kérjük, olvassa el alaposan ezt a telepítési kézikönyvet, mielőtt telepítené a légkondicionáló egységet.

PRIROČNIK ZA NAMESTITEV

Za varno in pravilno uporabo pred namestitvijo klimatske naprave skrbno preberite priročnik za namestitev.

MANUAL CU INSTRUCȚIUNI DE INSTALARE

Pentru o utilizare corectă și sigură, vă rugăm să citiți cu atenție acest manual înainte de a instala unitatea de aer condiționat.

PRIRUČNIK ZA UGRADNJU

Radi sigurne i ispravne uporabe, temeljito pročítajte ovaj priručnik prije ugradnje klimatizacijskog uređaja.

安装手册

为了安全和正确地使用本空调器，请在安装前仔细阅读本安装手册。

en

de

fr

nl

es

it

el

pt

da

sv

tr

bg

pl

no

ru

cs

sk

hu

sl

ro

hr

中<简>

[Fig. 2.2.1]

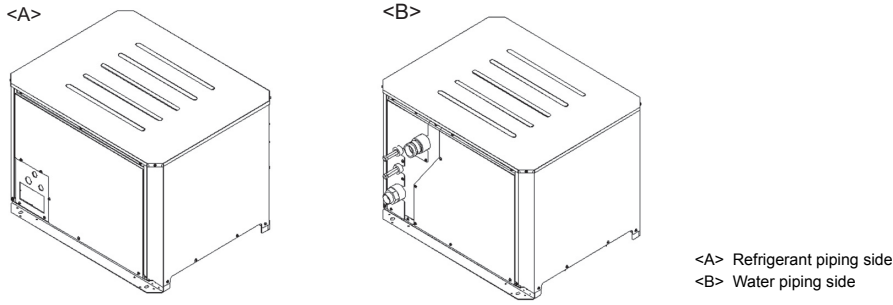

2.3

[Fig. 2.3.1]

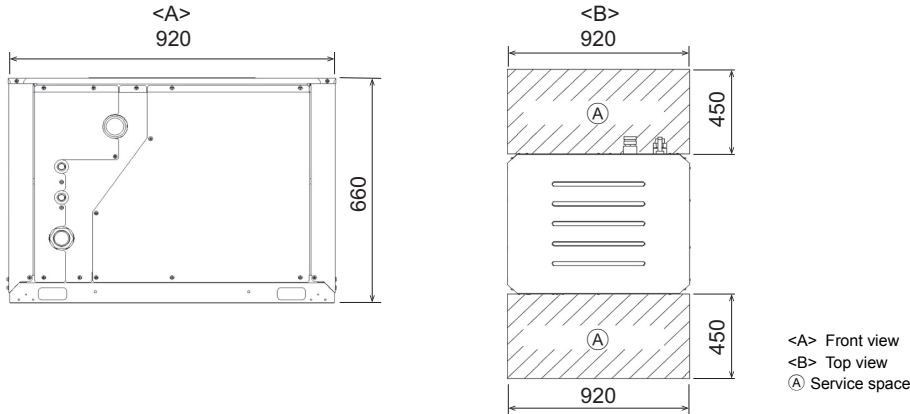

2.4

[Fig. 2.4.1]

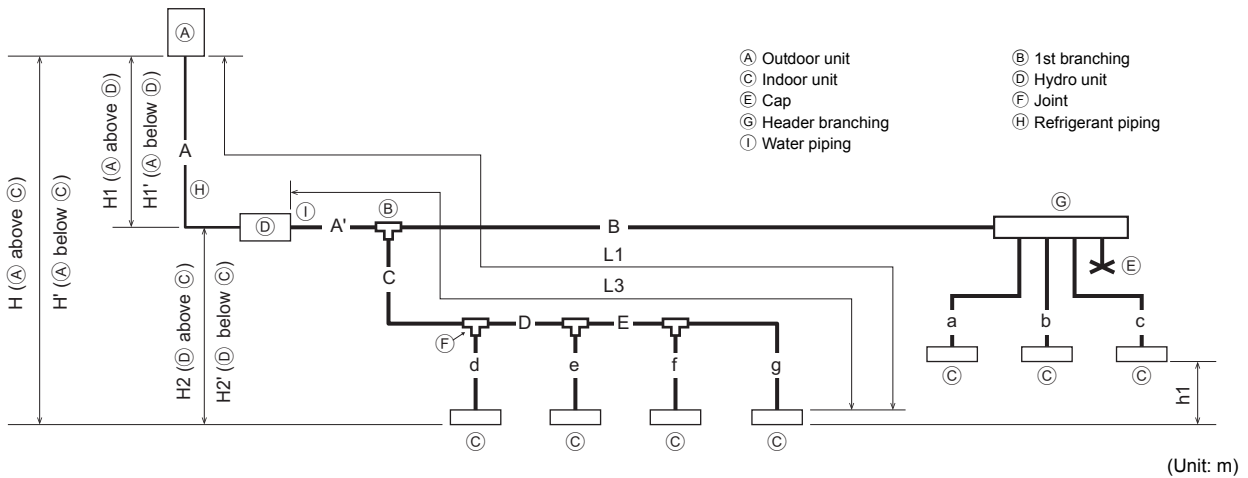

Item	Piping in the figure	Max. length	Max. equivalent length
Total piping length	$A+A'+B+C+D+E+a+b+c+d+e+f+g$	1000	-
Farthest indoor unit from outdoor unit (L1)	$A+A'+C+D+E+g/A+B+c$	165	190
Between outdoor unit and hydro unit (refrigerant pipework)	A	110	-
Farthest indoor unit from hydro unit (L3)	$A'+C+D+E+g/A'+B+c$	60	60
Height between outdoor unit and indoor unit (outdoor unit above indoor unit)	H	90	-
Height between outdoor unit and indoor unit (outdoor unit below indoor unit)	H'	60	-
Height between outdoor unit and hydro unit (outdoor unit above hydro unit)	H1	50 *1	-
Height between outdoor unit and hydro unit (outdoor unit below hydro unit)	H1'	40 *2	-
Height between hydro unit and indoor unit (hydro unit above indoor unit)	H2	50	-
Height between hydro unit and indoor unit (hydro unit below indoor unit)	H2'	40	-
Height between indoor units	h1	30	-

*1 The maximum length is 90 m, depending on the unit model and installation conditions. For more detailed information, contact your local distributor.

*2 The maximum length is 60 m, depending on the unit model and installation conditions. For more detailed information, contact your local distributor.

[Fig. 3.2.1]

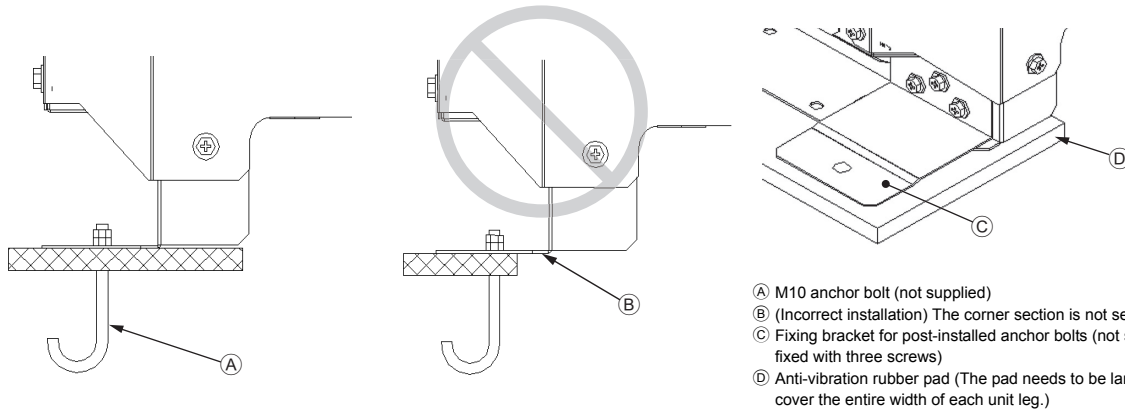

- A M10 anchor bolt (not supplied)
- B (Incorrect installation) The corner section is not securely received.
- C Fixing bracket for post-installed anchor bolts (not supplied) (To be fixed with three screws)
- D Anti-vibration rubber pad (The pad needs to be large enough to cover the entire width of each unit leg.)

[Fig. 4.1.1]

1. Hydro units connectable to outdoor units
Standard models

		Hydro unit	
Unit model		Model name	
Outdoor unit side	PUHY-M200		CMH-WM250V-A
	PUHY-M250	*1	
		*2	CMH-WM350V-A
	PUHY-M300	*3	
		*4	
	PUHY-M350		CMH-WM500V-A
	PUHY-M400	*5	
PUHY-M450			
PUHY-M500			

High-efficient models

		Hydro unit	
Unit model		Model name	
Outdoor unit side	PUHY-EM200		CMH-WM250V-A
	PUHY-EM250	*1	
		*2	CMH-WM350V-A
	PUHY-EM300	*3	
		*4	
	PUHY-EM350		CMH-WM500V-A
	PUHY-EM400	*5	
PUHY-EM450			
PUHY-EM500			

2. Connecting pipe diameter of outdoor unit
Standard models

		Liquid	Gas
Outdoor unit side	PUHY-M200	ø9.52 (ø3/8)	ø22.2 (ø7/8)
	PUHY-M250	*1 ø9.52 (ø3/8)	
		*2 ø12.7 (ø1/2)	
	PUHY-M300	*3 ø9.52 (ø3/8)	ø28.58 (ø1-1/8)
		*4 ø12.7 (ø1/2)	
	PUHY-M350	ø12.7 (ø1/2)	
	PUHY-M400	*5 ø12.7 (ø1/2)	
PUHY-M450	ø15.88 (ø5/8)		
PUHY-M500	ø15.88 (ø5/8)		

High-efficient models

		Liquid	Gas
Outdoor unit side	PUHY-EM200	ø9.52 (ø3/8)	ø22.2 (ø7/8)
	PUHY-EM250	*1 ø9.52 (ø3/8)	
		*2 ø12.7 (ø1/2)	
	PUHY-EM300	*3 ø9.52 (ø3/8)	ø28.58 (ø1-1/8)
		*4 ø12.7 (ø1/2)	
	PUHY-EM350	ø12.7 (ø1/2)	
	PUHY-EM400	*5 ø12.7 (ø1/2)	
PUHY-EM450	ø15.88 (ø5/8)		
PUHY-EM500	ø15.88 (ø5/8)		

3. Connecting pipe diameter of hydro unit

	Liquid	Gas
CMH-WM250V-A	ø9.52 (ø3/8)	ø22.2 (ø7/8)
CMH-WM350V-A	ø12.7 (ø1/2)	ø25.4 (ø1)
CMH-WM500V-A	ø15.88 (ø5/8)	ø25.4 (ø1)

If the connecting pipe diameter of hydro unit differs from that of outdoor unit, expand or reduce the pipe diameter at the inlet of the hydro unit.

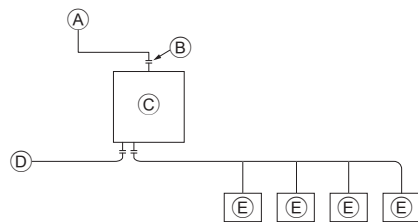

- A To outdoor unit
- B End connection (brazing)
- C Hydro unit
- D To main piping
- E Indoor unit

- *1 When the piping length from the outdoor unit to the hydro unit is less than 90 m (295 ft)
- *2 When the piping length from the outdoor unit to the hydro unit is 90 m (295 ft) or more
- *3 When the piping length from the outdoor unit to the hydro unit is less than 40 m (131 ft)
- *4 When the piping length from the outdoor unit to the hydro unit is 40 m (131 ft) or more
- *5 When the unit is used alone

4.1

[Fig. 4.1.2]

(1) When routing the pipes through the front of the unit

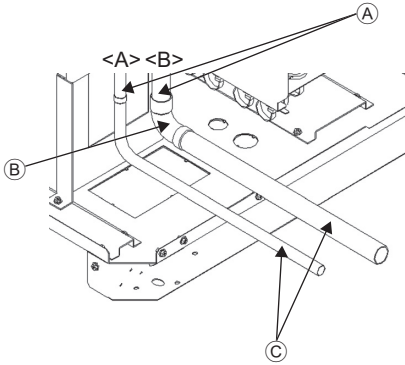

(2) When routing the pipes through the bottom of the unit

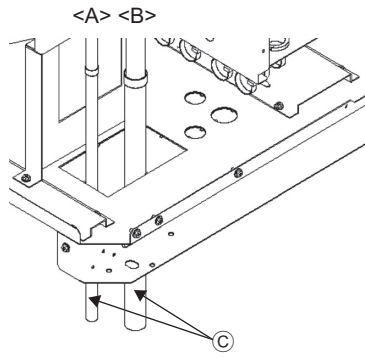

- <A> Liquid side
- Gas side
- Ⓐ Refrigerant piping
- Ⓑ Elbow
- Ⓒ On-site piping

(3) Pipe connection port and connecting pipe

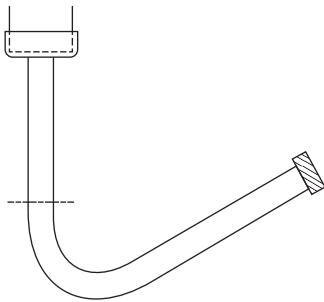

4.3

[Fig. 4.3.1]

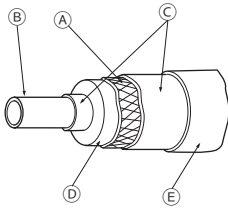

- Ⓐ Steel wire
- Ⓑ pipe
- Ⓒ Oily mastic asphalt or asphalt
- Ⓓ Insulation material A
- Ⓔ Outer covering B

Insulation material A	Glass fiber + Steel wire	
	Adhesive + Heat-resistant polyethylene foam + Adhesive tape	
Outer covering B	Indoor	Vinyl tape
	Under the floor and exposed	Waterproof hemp cloth + Bronze asphalt
	Outdoor	Waterproof hemp cloth + Zinc plate + Oily paint

* If a polyethylene cover is used as an outer covering, asphalt roofing is not necessary.

4.4

[Fig. 4.4.1]

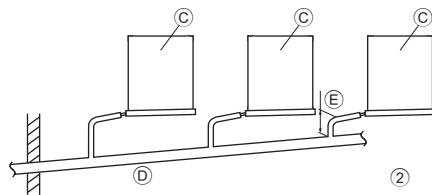
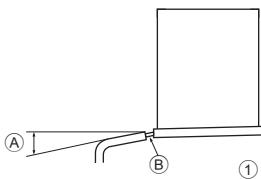

- Ⓐ Downward slope 1/100 or more
- Ⓑ Drain hose
- Ⓒ Unit
- Ⓓ Collective piping
- Ⓔ Maximize this length to approx. 10 cm
- * A drain pan is separately sold (for indoor use only).

[Fig. 5.1.1]

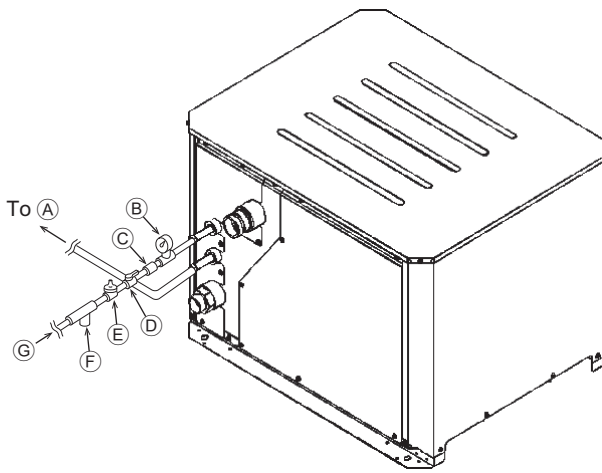

Hydro unit sample installation (*1)

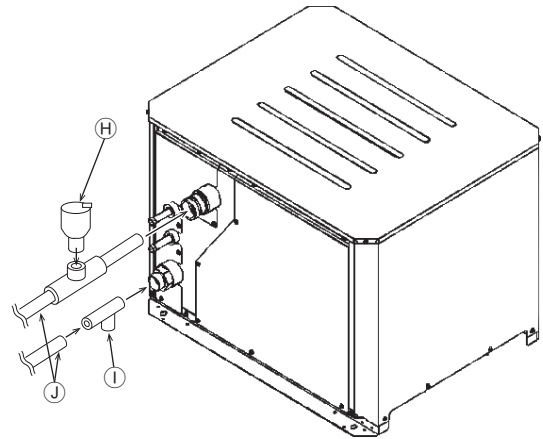

- (A) Expansion vessel (not supplied)
- (B) Pressure gauge (not supplied)
- (C) Check valve (not supplied)
- (D) Shutoff valve (not supplied)
- (E) Pressure reducing valve (not supplied)
- (F) Strainer (not supplied)
- (G) Water inlet
- (H) Auto air vent valve (supplied)
- (I) Strainer (supplied)
- (J) Water pipes

Note:

*1. Connect the pipes to the water pipes according to the local regulations.

[Fig. 5.1.2]

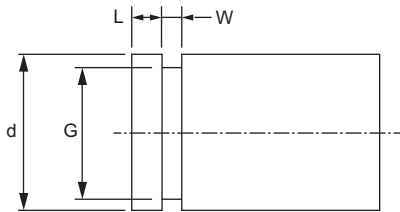

	Pipe size	
	40A	50A
d	ø48.6	ø60.3 ± 0.61
G	ø44.8 ⁺⁰ _{-0.7}	ø57.15 ⁺⁰ _{-0.38}
W	8 ± 0.5	7.95 ± 0.76
L	15 ^{+0.8} ₋₀	15.88 ± 0.76

[Fig. 5.1.3]

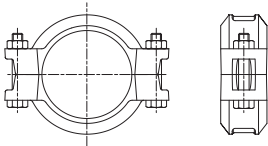

5.2

[Fig. 5.2.1]

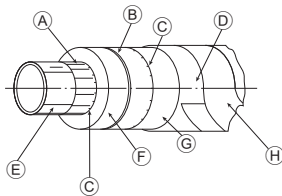

- (A) #7K tar felt
- (B) Steel wire
- (C) Blown asphalt
- (D) Base paper
- (E) Pipe
- (F) Glass wool
(Note: Absorbent material)
- (G) Asphalt felt
- (H) Cotton tape (After wrapping it around a pipe, brush polyester synthetic resin over the tape.)

[Fig. 5.2.2]

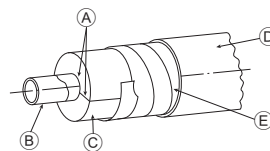

- (A) Adhesive (Completely fill joints of foam polystyrene pipe insulation and a gap between a pipe and foam polystyrene pipe insulation with adhesive.)
- (B) Pipe
- (C) Form polystyrene pipe insulation (Non-absorbent material)
- (D) Exterior (When pipes are installed on a roof, cover the pipes with galvanized steel sheets to protect the pipes from rainwater. This countermeasure is unnecessary when pipes are installed inside.)
- (E) Adhesive tape (Ensure that it has sufficient heat resistance so that high hot water temperature will not lower its adhesion.)

5.2

[Fig. 5.2.3]

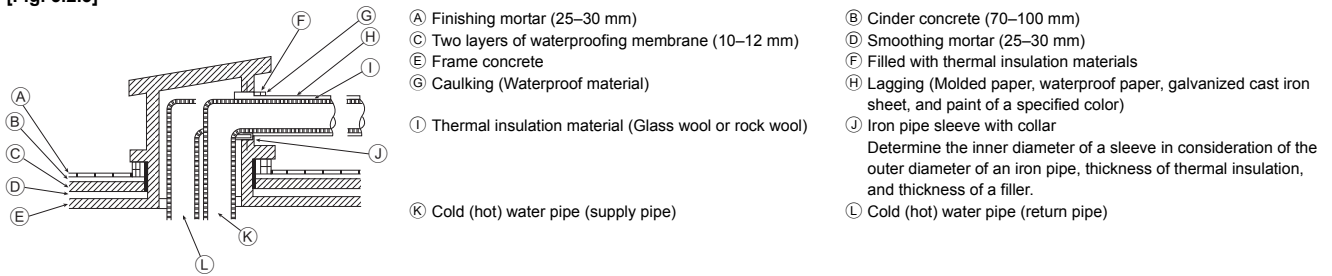

[Fig. 5.2.4]

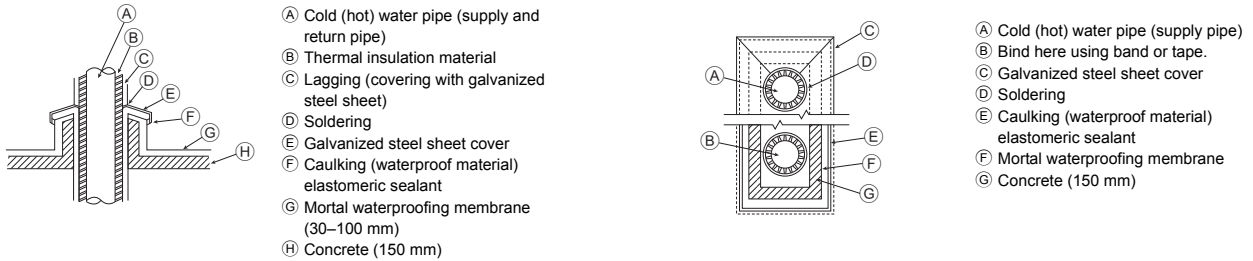

[Fig. 5.2.5]

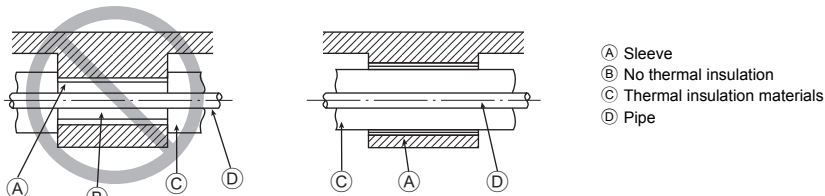

Thermal and cold insulation work on a pipe penetrating through a beam

[Fig. 5.2.6]

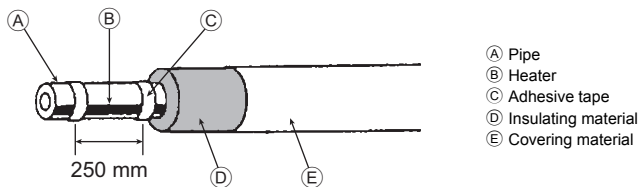

[Fig. 5.2.7]

Indoor unit	Connection size		Pipe size	
	Water inlet	Water outlet	Water return	Water out
PEFY-W-VMA	O.D. 22.0 mm	O.D. 22.0 mm	I.D. 20 mm	I.D. 20 mm

* For other indoor units, refer to the indoor unit installation manual.
 * The pipe diameter depends on the capacity of indoor units.
 Refer to the indoor unit installation manual for details.

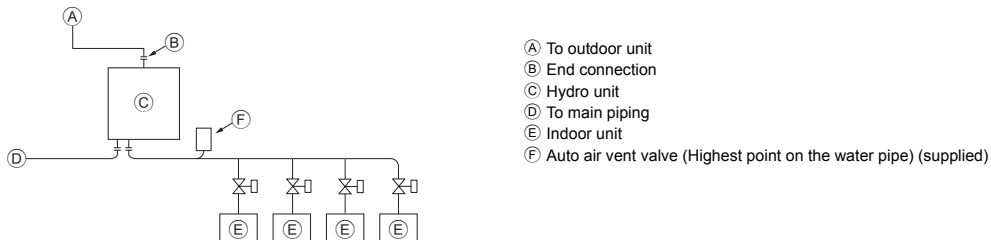

[Fig. 5.2.8]

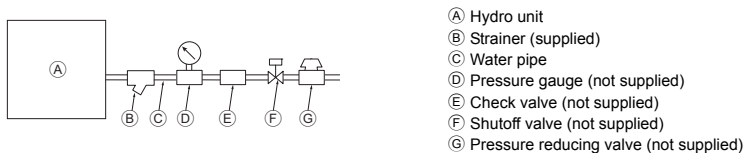

[Fig. 6.0.1]

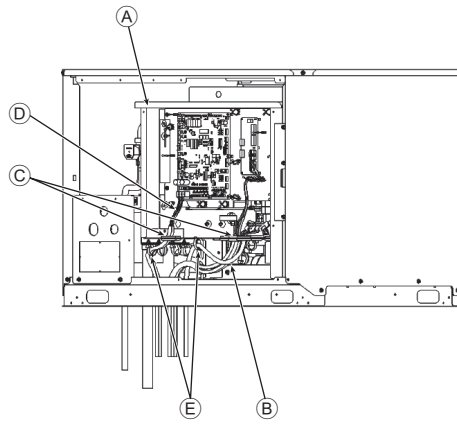
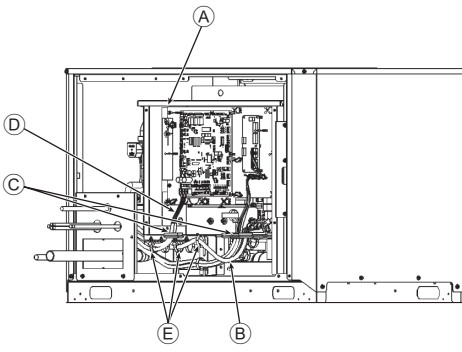

CMH-WM250V-A
CMH-WM350V-A
CMH-WM500V-A

- Ⓐ Control box
- Ⓑ Power source wiring
- Ⓒ ø32 hole (closed rubber bushing)
- Ⓓ Transmission wiring
- Ⓔ Clip cables here

1. Safety precautions	8	4. Connecting refrigerant pipes and drain pipes	11
1.1. Before installation and electric work	8	4.1. Connecting refrigerant pipes	11
1.2. Precautions for devices that use R32 refrigerant	9	4.2. Refrigerant piping work	12
1.3. Before installation	9	4.3. Insulating pipes	12
1.4. Before installation (relocation) - electrical work	9	4.4. Drain piping work	12
1.5. Before starting the test run	9	5. Connecting water pipework	13
2. Selecting an installation site	10	5.1. Important notes on water pipework installation	13
2.1. About the product	10	5.2. Water pipe insulation	13
2.2. Installation site	10	5.3. Water treatment and quality control	15
2.3. Securing installation and service space	10	6. Electrical work	15
2.4. Checking the installation site	10	7. Setting addresses and operating units	15
3. Installing the hydro unit	11	8. Test run	15
3.1. Checking the accessories with the hydro unit	11		
3.2. Installing hydro units	11		

1. Safety precautions

1.1. Before installation and electric work

- ▶ **Before installing the unit, make sure you read all the “Safety precautions”.**
- ▶ **The “Safety precautions” provide very important points regarding safety. Make sure you follow them.**

Symbols used in the text





Warning:

Describes precautions that should be observed to prevent danger of injury or death to the user.

Caution:

Describes precautions that should be observed to prevent damage to the unit.

Symbols used in the illustrations

-  : Indicates an action that must be avoided.
-  : Indicates that important instructions must be followed.
-  : Indicates a part which must be grounded.
-  : Beware of electric shock. (This symbol is displayed on the main unit label.)
<Color: Yellow>

Warning:

Carefully read the labels affixed to the main unit.

HIGH VOLTAGE WARNING:

- **Control box houses high-voltage parts.**
- **When opening or closing the front panel of the control box, do not let it come into contact with any of the internal components.**
- **Before inspecting the inside of the control box, turn off the power, keep the unit off for at least 10 minutes.**

Warning:

- **Ask the dealer or an authorized technician to install the air conditioner.**
 - Improper installation by the user may result in water leakage, electric shock, or fire.
- **Install the unit at a place that can withstand its weight.**
 - Failure to do so may cause the unit to fall down, resulting in injuries and damage to the unit.
- **Use the specified cables for wiring. Make the connections securely so that the outside force of the cable is not applied to the terminals.**
 - Inadequate connection and fastening may generate heat and cause a fire.
- **Prepare for earthquakes and install the unit at the specified place.**
 - Improper installation may cause the unit to fall down and result in injury and damage to the unit.
- **Always use accessories specified by Mitsubishi Electric.**
 - Ask an authorized technician to install the accessories. Improper installation by the user may result in water leakage, electric shock, or fire.
- **Never repair the unit. If the air conditioner must be repaired, consult the dealer.**
 - If the unit is repaired improperly, water leakage, electric shock, or fire may result.
- **If the supply cord is damaged, it must be replaced by the manufacturer, its service agent or similarly qualified persons in order to avoid a hazard.**
- **If refrigerant gas leaks during installation work or service, ventilate the room.**
 - If the refrigerant gas comes into contact with a flame, poisonous gases will be released.
- **Install the air conditioner according to this Installation Manual.**
 - If the unit is installed improperly, water leakage, electric shock, or fire may result.

- **Do not modify or adjust safety protection devices.**
 - Shorting of pressure or temperature switches to force operation may lead to damage, fire, explosions etc...
 - Do not change the set values as this may lead to damage, fire, explosions etc...
 - Use of any product except that specified by this company may lead to damage, fire, explosions etc...
- **Do not spray water on electrical parts.**
 - This could lead to shorting, fire, smoke, electrical shock, unit failure etc...
- **Do not create a situation where the refrigeration circuit is sealed yet incomplete with oil or refrigerant in the system.**
 - This may result in an explosion.
- **Do not touch electrical components during or directly after operation.**
 - This may lead to burns.
- **Put covers on control and terminal boxes.**
 - Shock due to ingress of dust, water, smoke, fire etc. may result.
 - During refrigerant recovery or purge, fire may result.
- **Do not operate with guards or panels removed.**
 - Injury due to rotating parts, electric shock due to high voltage or burns due to high temperatures may result.
- **Do no sit, ride or place objects on the unit.**
 - Injury due to the unit falling may result.
- **Use the appropriate safety gear.**
 - High voltages may result in electric shock.
 - Hot parts may result in burns.
- **Recover the refrigerant in the unit.**
 - Reuse the refrigerant or have it disposed of by a specialist.
 - Release of refrigerant may damage the environment.
- **Clear the pipework of remnant gas and oil.**
 - Failure to do so could lead to an eruption of flames and burns if the pipework is heated.
- **Vacuum dry the refrigerant pipework. Do not replace with a refrigerant that has not been specified.**
 - This could lead to explosions, fire.
- **Do not touch the onsite pipework ends.**
 - This could damage the pipework leading to refrigerant leaks and oxygen deficiency.
- **Have all electric work done by a licensed electrician according to “Electric Facility Engineering Standard” and “Interior Wire Regulations” and the instructions given in this manual and always use a dedicated power supply.**
 - If the power source capacity is inadequate or electric work is performed improperly, electric shock and fire may result.
- **Securely install the cover of control box.**
 - If the cover is not installed properly, dust or water may enter the outdoor unit and fire or electric shock may result.
- **When installing and moving the air conditioner to another site, do not charge it with a refrigerant different from the refrigerant specified on the unit.**
 - If a different refrigerant or air is mixed with the original refrigerant, the refrigerant cycle may malfunction and the unit may be damaged.
- **If the air conditioner is installed in a small room, measures must be taken to prevent the refrigerant concentration from exceeding the safety limit if the refrigerant should leak.**
 - Consult the dealer regarding the appropriate measures to prevent the safety limit from being exceeded. Should the refrigerant leak and cause the safety limit to be exceeded, hazards due to lack of oxygen in the room could result.
- **When moving and reinstalling the air conditioner, consult the dealer or an authorized technician.**
 - If the air conditioner is installed improperly, water leakage, electric shock, or fire may result.
- **After completing installation work, make sure that refrigerant gas is not leaking.**
 - If the refrigerant gas leaks and is exposed to a fan heater, stove, oven, or other heat source, it may generate noxious gases.

- **Do not reconstruct or change the settings of the protection devices.**
 - If the pressure switch, thermal switch, or other protection device is shorted or operated forcibly, or parts other than those specified by Mitsubishi Electric are used, fire or explosion may result.
- **To dispose of this product, consult your dealer.**
- **The installer and system specialist shall secure safety against leakage according to local regulation or standards.**
 - Choose the appropriate wire size and the switch capacities for the main power supply described in this manual if local regulations are not available.
- **Pay special attention to the place of installation, such as basement, etc. where refrigeration gas can accumulate, since refrigerant is heavier than the air.**
- **This appliance is not intended for use by persons (including children) with reduced physical, sensory or mental capabilities, or lack of experience and knowledge, unless they have been given supervision or instruction concerning use of the appliance by a person responsible for their safety.**
- **Children should be supervised to ensure that they do not play with the appliance.**
- **This appliance is intended to be used by expert or trained users in shops, in light industry and on farms, or for commercial use by lay persons.**
- **Do not repetitively turn on and off the unit in a short period.**
- **Wait until the power-supply voltage and the power-supply frequency stabilize before turning on the power supply.**

1.2. Precautions for devices that use R32 refrigerant

⚠ Caution:

- **Do not use existing refrigerant piping.**
 - The old refrigerant and refrigerant oil in the existing piping contain a large amount of chlorine which may cause the refrigerant oil of the new unit to deteriorate.
 - R32 is high-pressure refrigerant and can cause the existing piping to burst.
- **Use refrigerant piping made of phosphorus deoxidized copper and copper alloy seamless pipes and tubes. In addition, be sure that the inner and outer surfaces of the pipes are clean and free of hazardous sulphur, oxides, dust/dirt, shaving particles, oils, moisture, or any other contaminant.**
 - Contaminants on the inside of the refrigerant piping may cause the refrigerant residual oil to deteriorate.
- **Store the piping to be used during installation indoors and keep both ends of the piping sealed until just before brazing. (Store elbows and other joints in a plastic bag.)**
 - If dust, dirt, or water enters the refrigerant cycle, deterioration of the oil and compressor failure may result.
- **Apply a small amount of ester oil, ether oil, or alkyl benzene to flares. (for indoor unit)**
 - Infiltration of a large amount of mineral oil may cause the refrigerant oil to deteriorate.
- **Do not use a refrigerant other than R32.**
 - If another refrigerant (R22, etc.) is mixed with R32, the chlorine in the refrigerant may cause the refrigerant oil to deteriorate.
- **Use a vacuum pump with a reverse flow check valve.**
 - The vacuum pump oil may flow back into the refrigerant cycle and cause the refrigerant oil to deteriorate.
- **Do not use the following tools that are used with conventional refrigerants. (Gauge manifold, charge hose, gas leak detector, reverse flow check valve, refrigerant charge base, refrigerant recovery equipment)**
 - If the conventional refrigerant and refrigerant oil are mixed in the R32, the refrigerant may deteriorate.
 - If water is mixed in the R32, the refrigerant oil may deteriorate.
 - Since R32 does not contain any chlorine, gas leak detectors for conventional refrigerants will not react to it.
- **Refrigerant R32 is flammable. Do not use a naked-flame type detector.**
- **Carry a refrigerant leak detection sensor when installing or removing the unit.**
- **Do not use a charging cylinder.**
 - Using a charging cylinder may cause the refrigerant to deteriorate.
- **Do not use antioxidant or leak-detection additive.**
- **Be especially careful when managing the tools.**
 - If dust, dirt, or water gets into the refrigerant cycle, the refrigerant may deteriorate.

1.3. Before installation

⚠ Caution:

- **Do not install the unit where combustible gas may leak.**
 - If the gas leaks and accumulates around the unit, an explosion may result.
- **Do not use the air conditioner where food, pets, plants, precision instruments, or artwork are kept.**
 - The quality of the food, etc. may deteriorate.
- **Do not use the air conditioner in special environments.**
 - Oil, steam, sulfuric smoke, etc. can significantly reduce the performance of the air conditioner or damage its parts.

- **When installing the unit in a hospital, communication station, or similar place, provide sufficient protection against noise.**
 - Sound pressure level does not exceed 70 dB(A). However, inverter equipment, private power generator, high-frequency medical equipment, or radio communication equipment may cause the air conditioner to operate erroneously, or fail to operate. On the other hand, the air conditioner may affect such equipment by creating noise that disturbs medical treatment or image broadcasting.
- **Do not install the unit on or over things that are subject to water damage.**
 - When the room humidity exceeds 80% or when the drain pipe is clogged, condensation may drip from the indoor unit or hydro unit. Perform collective drainage work together with the outdoor unit, as required.
- **Do not install the unit where corrosive gas may be generated.**
 - Doing so can corrode the pipes, resulting in refrigerant leakage and fire.
- **Check that markings of the unit are not illegible.**
 - Illegible warning or caution markings may cause damage to the unit, resulting in injury.

1.4. Before installation (relocation) - electrical work

⚠ Caution:

- **Ground the unit.**
 - Do not connect the ground wire to gas or water pipes, lightning rods, or telephone ground lines. Improper grounding may result in electric shock.
- **Install the power cable so that tension is not applied to the cable.**
 - Tension may cause the cable to break and generate heat and cause a fire.
- **Install a leak circuit breaker, as required.**
 - If a leak circuit breaker is not installed, electric shock may result.
- **Use power line cables of sufficient current carrying capacity and rating.**
 - Cables that are too small may leak, generate heat, and cause a fire.
- **Use only a circuit breaker and fuse of the specified capacity.**
 - A fuse or circuit breaker of a larger capacity, or the use of substitute simple steel or copper wire may result in a general unit failure or fire.
- **Do not wash the air conditioner units.**
 - Washing them may cause an electric shock.
- **Be careful that the installation base is not damaged by long use.**
 - If the damage is left uncorrected, the unit may fall and cause personal injury or property damage.
- **Install the drain piping according to this Installation Manual to ensure proper drainage. Wrap thermal insulation around the pipes to prevent condensation.**
 - Improper drain piping may cause water leakage causing damage to furniture and other possessions.
- **Be very careful about transporting the product.**
 - One person should not carry the product. Its weight is in excess of 20 kg.
 - Some products use PP bands for packaging. Do not use any PP bands as a means of transportation. It is dangerous.
- **Safely dispose of the packing materials.**
 - Packing materials, such as nails and other metal or wooden parts, may cause stabs or other injuries.
 - Tear apart and throw away plastic packaging bags so that children will not play with them. If children play with a plastic bag which has not been torn apart, they face the risk of suffocation.
- **When air flow decrease is detected of a circulation fan beside the hydro unit installed at the height of less than 1.8 m from the ground, the system must be powered off within 10 seconds from the detection. Before powering off the system, connect the contactor to the power cable of the outdoor unit and open the contactor. For the connection procedures, specifications, and installation location of the contactor, refer to the manual of the outdoor unit.**

1.5. Before starting the test run

⚠ Caution:

- **Turn on the power at least 12 hours before starting operation.**
 - Starting operation immediately after turning on the main power switch can result in irreversible damage to internal parts. Keep the power switch turned on during the operational season.
- **Do not touch the switches with wet fingers.**
 - Touching a switch with wet fingers can result in an electric shock.
- **Do not touch the refrigerant pipes during and immediately after operation.**
 - During and immediately after operation, the refrigerant pipes may be hot or cold, depending on the condition of the refrigerant flowing through the refrigerant piping, compressor, and other refrigerant cycle parts. Your hands may suffer burns or frostbite if you touch the refrigerant pipes.
- **Do not operate the air conditioner with the panels and guards removed.**
 - Rotating, hot, or high-voltage parts can cause injuries.
- **Do not turn off the power immediately after stopping operation.**
 - Always wait at least 5 minutes before turning off the power. Otherwise, drainage water leakage or mechanical failure of sensitive parts may occur.
- **Check for refrigerant leaks before service.**
 - If the refrigerant leaks, fire may result.

2. Selecting an installation site

2.1. About the product

- This unit uses R32-type refrigerant.
- Only the "W" models of indoor units can be connected.
- Piping for systems using R32 may be different from that for systems using conventional refrigerant because the design pressure in systems using R32 is higher. Refer to the Data Book for more information.
- Some of the tools and equipment used for installation with systems that use other types of refrigerant cannot be used with the systems using R32. Refer to the Data Book for more information.
- Do not use the existing piping, as it contains chlorine, which is found in conventional refrigerating machine oil and refrigerant. This chlorine will deteriorate the refrigerant machine oil in the new equipment. The existing piping must not be used as the design pressure in systems using R32 is higher than that in the systems using other types of refrigerant and the existing pipes may burst.

2.2. Installation site

- Observe the following precautions when installing the hydro unit outside.
- Install the unit with adequate space around it for servicing.
- Do not install the unit in a place that would result in the piping length restrictions being exceeded.
- Check for refrigerant leaks before service.
 - If the refrigerant leaks, fire may result.
- Install or store the unit in a place not exposed to direct radiant heat from other heat sources or naked flame or other ignition sources.
- Do not install the unit in any oily steamy place or near any machine that generates high frequencies. Doing so may cause a risk of fire, erroneous operation or condensation.
- Do not install the unit where it could be salt-damaged.
- Depending on the operation conditions, hydro unit generates noise caused by water pump even when operating normally. Therefore install the unit in places such as machinery room that follows EUROPEAN STANDARD.
- Install indoor unit and hydro unit at least 5 m away from each other when installed in a space with low background noise, e.g., hotel rooms.
- Allow enough space and access to ensure water piping, refrigerant piping and electrical wiring can be easily connected.
- Avoid places exposed to the generation, inflow, accumulation or leakage of flammable and sulfuric gases.
- Ensure a downward gradient of at least 1/100 for drain piping.
- Properly install the unit on a stable, load-bearing surface.

1. Hydro unit Top view [Fig. 2.2.1] (P.2)

<A> Refrigerant piping side
 Water piping side

- Provide 2 inspection holes 450 mm square in the ceiling surface as shown in [Fig. 2.3.1] (P.2).
- Install the unit in a suitable location (such as machinery room that follows EUROPEAN STANDARD) away from places regularly occupied. Avoid installing in the occupied space.
- If necessary, install the unit on a raised base of the following specifications (not supplied) to prevent damage from snow.
 - Material: Angle iron (Build a structure that snow and wind can pass through.)
 - Height: Expected maximum snowfall plus 200 mm (7-7/8 in)
 - Width: Within the unit width (If the raised base is too wide, snow will accumulate on the raised base.)
- When the unit is used in a cold region and the heating operation is continuously performed for a long time when the outside air temperature is below freezing, install a heater on the raised base or take other appropriate measures to prevent water from freezing on the raised base.
- When installing a panel heater, provide sufficient space for maintenance accordingly. For details, refer to the Data Book or installation manual for the panel heater.

⚠ Warning:

Be sure to install the unit in a place that can sustain the entire weight. If there is a lack of strength, it may cause the unit to fall down, resulting in an injury.

⚠ Caution:

- Be sure to install the unit horizontally. Install the hydro unit level (less than 1° tilt), so that the drain pan can function correctly.
- Install the hydro unit in an environment where the temperature is always above 0°C if water circuit does not contain antifreeze liquid.

2.3. Securing installation and service space

- Allow for the following service space after installation (Servicing can be performed from the front and back of the unit.)

[Fig. 2.3.1] (P.2)

<A> Front view Top view
(A) Service space

2.4. Checking the installation site

Check that the difference of elevation between indoor and outdoor units and the length of refrigerant piping are within the following limitations.

1. CMH-WM*V-A

[Fig. 2.4.1] (P.2)

(A) Outdoor unit (B) 1st branching
(C) Indoor unit (D) Hydro unit
(E) Cap (F) Joint
(G) Header branching (H) Refrigerant piping
(I) Water piping

(Unit: m)

Item	Piping in the figure	Max. length	Max. equivalent length
Total piping length	A+A'+B+C+D+E+a+b+c+d+e+f+g	1000	-
Farthest indoor unit from outdoor unit (L1)	A+A'+C+D+E+g/A+B+c	165	190
Between outdoor unit and hydro unit (refrigerant pipework)	A	110	-
Farthest indoor unit from hydro unit (L3)	A'+C+D+E+g/A'+B+c	60	60
Height between outdoor unit and indoor unit (outdoor unit above indoor unit)	H	90	-
Height between outdoor unit and indoor unit (outdoor unit below indoor unit)	H'	60	-
Height between outdoor unit and hydro unit (outdoor unit above hydro unit)	H1	50 *1	-
Height between outdoor unit and hydro unit (outdoor unit below hydro unit)	H1'	40 *2	-
Height between hydro unit and indoor unit (hydro unit above indoor unit)	H2	50	-
Height between hydro unit and indoor unit (hydro unit below indoor unit)	H2'	40	-
Height between indoor units	h1	30	-

*1 The maximum length is 90 m, depending on the unit model and installation conditions. For more detailed information, contact your local distributor.

*2 The maximum length is 60 m, depending on the unit model and installation conditions. For more detailed information, contact your local distributor.

⚠ Warning:

(When R32 refrigerant is used)

- Do not use means to accelerate the defrosting process or to clean, other than those recommended by the manufacturer.
- The unit shall be stored in a room without continuously operating ignition sources (for example: open flames, an operating gas appliance or an operating electric heater.)
- Do not pierce or burn.
- Be aware that refrigerants may not contain an odour.
- When installing a hydro unit in an unoccupied space or outdoors, take safety measures in accordance with the European Standard, based on the system refrigerant amount and the room volume as shown in the figure below. (The installation restrictions can be simply found by using the flowchart provided on a separate sheet.)

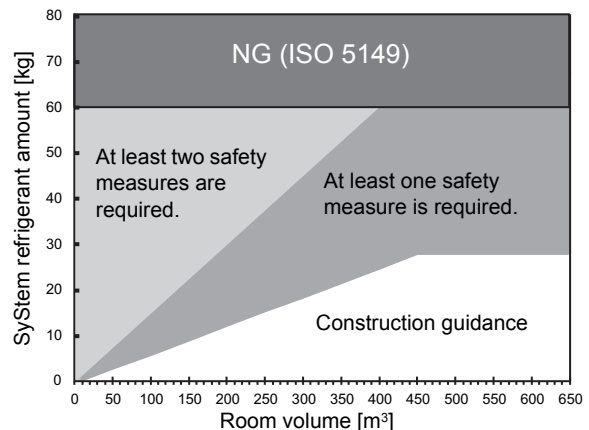

Notes:

- Refer to the outdoor unit manual about additional refrigerant amount of hydro unit and maximum amount of system refrigerant.
- Be sure to protect pipings from physical damage.

3. Installing the hydro unit

3.1. Checking the accessories with the hydro unit

The following items are supplied with each hydro unit.

		Model name		
		CMH-WM250V-A		
		CMH-WM350V-A		
		CMH-WM500V-A		
Item			Qty	
①	Installation manual		1	
②	Air vent manual		1	
③	Auto air vent valve (3/4 parallel thread)		1	
④	Strainer (20 mesh)	W250 W350	32A screw-in housing (40A)	1
		W500	40A screw-in housing (50A)	1
⑤	Refrigerant connection pipe	W350 W500	ø25.4 – ø28.58 (ø1 – ø1-1/8)	1

3.2. Installing hydro units

Bases

- Be sure to install unit in a place strong enough to withstand its weight. If the base is unstable, reinforce with a concrete base.
- The unit must be anchored on a level surface. Use a level to check after installation.
- If the unit is installed near a room where noise is a problem, using an anti-vibration stand on the base of the unit is recommended.

[Fig. 3.2.1] (P.3)

- Ⓐ M10 anchor bolt (not supplied)
- Ⓑ (Incorrect installation) The corner section is not securely received.
- Ⓒ Fixing bracket for post-installed anchor bolts (not supplied) (To be fixed with three screws)
- Ⓓ Anti-vibration rubber pad (The pad needs to be large enough to cover the entire width of each unit leg.)

⚠ Warning:

- **Be sure to install unit in a place strong enough to withstand its weight. Any lack of strength may cause unit to fall down, resulting in a personal injury.**
- **Have installation work in order to protect against earthquake. Any installation deficiency may cause unit to fall down, resulting in a personal injury.**
- ▶ **Be sure to install the hydro unit horizontally. Check using a level. If the unit is installed at an angle, drain water may leak out.**

⚠ Caution:

- **Be sure to install the unit horizontally. Install the hydro unit level (less than 1° tilt), so that the drain pan (option) can function correctly.**

4. Connecting refrigerant pipes and drain pipes

4.1. Connecting refrigerant pipes

1. Be sure to use non-oxidative brazing where necessary. If you do not use non-oxidative brazing, it may clog the pipes.
When brazing the outdoor unit connecting port of hydro unit, supply nitrogen gas into the pipe between the outdoor unit and hydro unit.
2. After completing pipe connection, support the pipes to ensure that load is not imparted to the hydro unit's end connections.
3. When using mechanical couplings, use the ones that meet ISO14903.

⚠ Warning:

When installing and moving the unit, do not charge it with refrigerant other than the refrigerant (R32) specified on the unit.

- Mixing of a different refrigerant, air, etc. may cause the refrigerant cycle to malfunction and result in severe damage.

⚠ Caution:

- **Use refrigerant piping made of phosphorus deoxidized copper and copper alloy seamless pipes and tubes. In addition, be sure that the inner and outer surfaces of the pipes are clean and free of hazardous sulphur, oxides, dust/dirt, swarf, oils, moisture, or any other contaminants.**
 - R32 is high-pressure refrigerant and can cause the existing piping to burst.
- **Store the piping to be used during installation hydro unit and keep both ends of the piping sealed until just before brazing. (Store elbows and other joints in a plastic bag.)**
 - If dust, dirt, or water enters the refrigerant cycle, deterioration of the oil and compressor failure may result.
 - Infiltration of a large amount of mineral oil may cause the refrigerant oil to deteriorate.
- **Do not vent R32 into the atmosphere.**

1. Size of hydro unit's end connection piping

[Fig. 4.1.1] (P.3)

1. Hydro units connectable to outdoor units

Standard models

High-efficient models

		Hydro unit		
		Unit model	Model name	
Outdoor unit side	PUHY-M200	CMH-WM250V-A		
	PUHY-M250			*1
				*2
	PUHY-M300			*3
				*4
	PUHY-M350			CMH-WM350V-A
PUHY-M400	*5			
PUHY-M450	CMH-WM500V-A			
PUHY-M500				

		Hydro unit		
		Unit model	Model name	
Outdoor unit side	PUHY-EM200	CMH-WM250V-A		
	PUHY-EM250			*1
				*2
	PUHY-EM300			*3
				*4
	PUHY-EM350			CMH-WM350V-A
PUHY-EM400	*5			
PUHY-EM450	CMH-WM500V-A			
PUHY-EM500				

2. Connecting pipe diameter of outdoor unit

Standard models

High-efficient models

		Unit model	Liquid	Gas	
Outdoor unit side	PUHY-M200	ø9.52 (ø3/8)	ø9.52 (ø3/8)	ø22.2 (ø7/8)	
	PUHY-M250				*1
					*2
	PUHY-M300				*3
					*4
	PUHY-M350				ø12.7 (ø1/2)
PUHY-M400	*5				
PUHY-M450	ø15.88 (ø5/8)	ø15.88 (ø5/8)			
PUHY-M500					

		Unit model	Liquid	Gas	
Outdoor unit side	PUHY-EM200	ø9.52 (ø3/8)	ø9.52 (ø3/8)	ø22.2 (ø7/8)	
	PUHY-EM250				*1
					*2
	PUHY-EM300				*3
					*4
	PUHY-EM350				ø12.7 (ø1/2)
PUHY-EM400	*5				
PUHY-EM450	ø15.88 (ø5/8)	ø15.88 (ø5/8)			
PUHY-EM500					

3. Connecting pipe diameter of hydro unit

	Liquid	Gas
CMH-WM250V-A	ø9.52 (ø3/8)	ø22.2 (ø7/8)
CMH-WM350V-A	ø12.7 (ø1/2)	ø25.4 (ø1)
CMH-WM500V-A	ø15.88 (ø5/8)	ø25.4 (ø1)

If the connecting pipe diameter of hydro unit differs from that of outdoor unit, expand or reduce the pipe diameter at the inlet of the hydro unit.

*1 When the piping length from the outdoor unit to the hydro unit is less than 90 m (295 ft)

*2 When the piping length from the outdoor unit to the hydro unit is 90 m (295 ft) or more

*3 When the piping length from the outdoor unit to the hydro unit is less than 40 m (131 ft)

*4 When the piping length from the outdoor unit to the hydro unit is 40 m (131 ft) or more

*5 When the unit is used alone

- Ⓐ To outdoor unit
- Ⓑ End connection (brazing)
- Ⓒ Hydro unit
- Ⓓ To main piping
- Ⓔ Indoor unit

Note:

- **Be sure to use non-oxidative brazing.**

<Refrigerant piping connection examples>

- Obtain joints and elbows on site as necessary according to the pipe diameter, and connect the pipes as shown in the figures below.

[Fig. 4.1.2] (P.4)

- (1) When routing the pipes through the front of the unit
- (2) When routing the pipes through the bottom of the unit
- (3) Pipe connection port and connecting pipe

<A> Liquid side
 Gas side

- Ⓐ Refrigerant piping
- Ⓑ Elbow
- Ⓒ On-site piping

4.2. Refrigerant piping work

After connecting the refrigerant pipes of the outdoor units with the outdoor units' stop valves remained fully closed, evacuate vacuum from the outdoor units' stop valve service ports.

After completing the above, open the outdoor units' stop valves. This connects the refrigerant circuit (between outdoor and hydro unit) completely.

How to handle stop valves is described on each outdoor unit.

Notes:

- **Have a fire extinguisher nearby before brazing work.**
- **Provide no-smoking signs at the brazing workplace.**
- **After pipe connection, be sure to check that there is no gas leakage, using a leak detector or soap-and-water solution.**
- **Before brazing the refrigerant piping, always wrap the piping on the main body, and the thermal insulation piping, with damp cloths to prevent heat shrinkage and burning the thermal insulation tubing.** Take care to ensure that the flame does not come into contact with the main body itself.
- **Do not use leak-detection additives.**
- **Straight run of pipe connecting twinning pipe is 500 mm or more.**
- **Piping work shall be kept to a minimum.**
- **The pipes shall be protected from physical damage.**

⚠ Warning:

Do not mix anything other than the specified refrigerant (R32) into the refrigerating cycle when installing or moving. Mixing air may cause the refrigerating cycle to reach abnormally high temperature, resulting in burst pipes.

⚠ Caution:

Cut the tip of the outdoor unit piping, remove the gas, and then remove the brazed cap.

4.3. Insulating pipes

Be sure to add insulation work to piping by covering high-temperature pipe and low-temperature pipe separately with enough thickness heat-resistant polyethylene foam, so that no gap is observed in the joint between the hydro unit and insulating material, and insulating materials themselves. When insulation work is insufficient, there is a possibility of condensation. Pay special attention to insulation work in the ceiling plenum.

[Fig. 4.3.1] (P.4)

- Ⓐ Steel wire
- Ⓑ pipe
- Ⓒ Oily mastic asphalt or asphalt
- Ⓓ Insulation material A
- Ⓔ Outer covering B

Insulation material A	Glass fiber + Steel wire	
	Adhesive + Heat-resistant polyethylene foam + Adhesive tape	
Outer covering B	Indoor	Vinyl tape
	Under the floor and exposed	Waterproof hemp cloth + Bronze asphalt
	Outdoor	Waterproof hemp cloth + Zinc plate + Oily paint

* If a polyethylene cover is used as an outer covering, asphalt roofing is not necessary.

- Insulation materials for the pipes to be added on site must meet the following specifications:

Outdoor unit	High-pressure pipe	10 mm or more
-Hydro unit	Low-pressure pipe	20 mm or more
Temperature Resistance	100°C min.	

- Installation of pipes in a high-temperature high-humidity environment, such as the top floor of a building, may require the use of insulation materials thicker than the ones specified in the chart above.
- When certain specifications presented by the client must be met, ensure that they also meet the specifications on the chart above.
- The brazed connections must be covered with insulation, with its seam facing upward and fastened with the bands.

4.4. Drain piping work

Drain or condensation water will be discharged from hydro units during test run. If this will be a problem, install a separately sold drain pan, following the procedures explained below for connecting drain piping.

1. Drain piping work

- Ensure that the drain piping is downward (sloped gradient of more than 1/100) to the outdoor (discharge) side. If it is impossible to take any downward pitch, use an optionally available drain-up mechanism to obtain a downward pitch of more than 1/100.
- Ensure that any cross-wise drain piping is less than 20 m. If the drain piping is long, support it with metal brackets to prevent it from bending, warping, or vibrating.
- Ensure that collected pipes are 10 cm lower than the unit body's drain port as shown in ②.
- Do not put the end of the drain piping in any drain where ionic gases are generated. (Drain pan: optional parts)
- Do not use any odor trap around the discharge port.

[Fig. 4.4.1] (P.4)

- Ⓐ Downward slope 1/100 or more
- Ⓑ Drain hose
- Ⓒ Unit
- Ⓓ Collective piping
- Ⓔ Maximize this length to approx. 10 cm
- * A drain pan is separately sold (for indoor use only).

- Set the end of drain piping in a place without any risk of odor generation.
- Drain piping may be installed in any direction. However, please be sure to observe the above instructions.

2. Discharge test

After completing drain piping work, test drain discharge using a small amount of water. Also, check to see that there is no water leakage from the connections.

3. Insulating drain pipes

Provide sufficient insulation to the drain pipes just as for refrigerant pipes.

⚠ Caution:

Be sure to provide drain piping with heat insulation in order to prevent excess condensation. Without drain piping, water may leak from the unit causing damage to your property.

5. Connecting water pipework

Please observe the following precautions during installation.

5.1. Important notes on water pipework installation

- The design pressure of the hydro unit water system is 0.8 MPa.
- Use water pipe-work with a design pressure of at least 0.8 MPa.
- When performing a water leak check, please do not allow the water pressure to go above 0.8 MPa.
- Perform a pressure test on the field-installed water pipes at a pressure equal to 1.5 times the design pressure. Before performing a pressure test, isolate the pipes from hydro unit and indoor units.
- Please connect the water pipework of each indoor unit to the correct port on the hydro unit. Failure to do so will result in incorrect running.
- Provide some joints and valves around inlet/outlet of each unit for easy maintenance, checkup, and replacement.
- Install a suitable air vent valve (supplied) on the water pipe. After flowing water through the pipe, vent any excess air. Add air vent valves where air gaps occur as necessary on site.
- After the completion of test run, make sure not to reintroduce air into the pipe.
- Secure the pipes with metal fitting, positioning them in locations to protect pipes against breakage and bending.
- Do not confuse the water intake and outlet piping especially when connecting the hydro unit.
(Error code 5102 will appear on the remote controller if a test run is performed with the pipe-work installed incorrectly (inlet connected to outlet and vice versa).)
- The unused knockout holes should be closed and the refrigerant pipes, water pipes, power source and transmission wires access holes should be filled with putty.
- Install water pipe so that the water flow rate will be maintained.
- Wrap sealing tape as follows.
 - Wrap the joint with sealing tape following the direction of the threads (clockwise), do not wrap the tape over the edge.
 - Overlap the sealing tape by two-thirds to three-fourths of its width on each turn. Press the tape with your fingers so that it is tight against each thread.
 - Do not wrap the 1.5th through 2nd farthest threads away from the pipe end.
- Hold the pipe on the unit side in place with a spanner when installing the pipes or strainer. Tighten screws to a torque of 40 N·m.
- If there is a risk of freezing, carry out a procedure to prevent it.
- Use copper, plastic, steel, or stainless steel pipes for the water circuit. Furthermore, when using copper pipe-work, use a non-oxidative brazing method. Oxidation of the pipe-work will reduce the pump life. When using iron or stainless-steel pipework, ensure that rust from the pipework does not enter the unit.
- Connect the pipe and the unit so that the pipe does not interfere with maintenance and sufficient space is left for maintenance.
- Add water pressure gauge to see if the water pressure in hydro unit is correct or not.
- Be sure to braze the water pipes after covering a wet cloth to the insulation pipes of the units in order to prevent them from burning and shrinking by heat.** (There are some plastic parts in hydro unit.)
- Install the unit so that external force is not applied to the water pipes.**
- Do not operate the pump before the pipes are filled with water.**
- After filling the pipes with water, immediately perform debris removal operation and air vent operation.

Example of hydro unit installation

[Fig. 5.1.1] (P.5)

- | | |
|--|------------------------------------|
| (A) Expansion vessel (not supplied) | (B) Pressure gauge (not supplied) |
| (C) Check valve (not supplied) | (D) Shutoff valve (not supplied) |
| (E) Pressure reducing valve (not supplied) | (F) Strainer (not supplied) |
| (G) Water inlet | (H) Auto air vent valve (supplied) |
| (I) Strainer (supplied) | (J) Water pipes |

Note:

- *1. Connect the pipes to the water pipes according to the local regulations.

(Connecting the pipes using coupling housings)

- Connect the pipes as follows when connecting them with coupling housings. The hydro-unit side of the pipe has a groove so that it can be connected to the unit with coupling housings.

[Fig. 5.1.2] (P.5)

- Machine a groove on a nipple on site.
Machine a groove in the size listed below on the on-site pipe for fitting coupling housings.

	Pipe size	
	40A	50A
d	ø48.6	ø60.3 ± 0.61
G	ø44.8 ⁺⁰ _{-0.7}	ø57.15 ⁺⁰ _{-0.38}
W	8 ± 0.5	7.95 ± 0.76
L	15 ^{+0.8} ₋₀	15.88 ± 0.76

[Fig. 5.1.3] (P.5)

- Apply soap water to the chiller-side pipe, and fit the rubber ring in the groove, using caution not to damage the ring.
- Insert the pipe with the grooved nipple into the rubber ring, using caution not to damage the rubber ring.
Hold the pipe into place so that the pipe will not sag to keep the rubber packing from being damaged.
- Fit the housings in the grooves on the chiller-side pipe and the on-site pipe, and hold them together with bolts and nuts.

Note:

- Use caution not to mix up the water inlet and outlet.
- Install a coupling valve on the pipe to allow access for maintenance.
- Install a flexible joint on the pipe to keep the vibration of the unit from being transmitted to the pipe.
- Install the supplied strainer in the inlet pipe on the unit to keep foreign objects (e.g., bolts and stones) out of the water-side heat exchanger.
- Route the piping so that the pipes will not interfere with replacement of internal components (e.g., pumps) of the unit.

5.2. Water pipe insulation

1. Thermal insulation work on pipes

Cold (hot) water pipes require thermal insulation to prevent condensation on the pipe surface while especially in the cooling mode as well as heat emission from and penetration into the pipes.

- Example of thermal insulation work on pipes using glass wool

[Fig. 5.2.1] (P.5)

- | | |
|---|---|
| (A) #7K tar felt | (B) Steel wire |
| (C) Blown asphalt | (D) Base paper |
| (E) Pipe | (F) Glass wool (Note: Absorbent material) |
| (G) Asphalt felt | |
| (H) Cotton tape (After wrapping it around a pipe, brush polyester synthetic resin over the tape.) | |

- Example of thermal insulation work on pipes using foam polystyrene pipe insulation

[Fig. 5.2.2] (P.5)

- Adhesive (Completely fill joints of foam polystyrene pipe insulation and a gap between a pipe and foam polystyrene pipe insulation with adhesive.)
 - Pipe
 - Form polystyrene pipe insulation (Non-absorbent material)
 - Exterior (When pipes are installed on a roof, cover the pipes with galvanized steel sheets to protect the pipes from rainwater. This countermeasure is unnecessary when pipes are installed inside.)
 - Adhesive tape (Ensure that it has sufficient heat resistance so that high hot water temperature will not lower its adhesion.)

- Waterproofing of pipe penetration

Penetrating waterproofing membrane with pipes or sleeves may cause a roof leak when cold (hot) water pipes are connected to units installed on a roof. To prevent such roof leak, perform construction work on where pipes stick out of the roof as shown in the figure below.

- Example of construction work on a roof pipe shaft when constructing a new building

[Fig. 5.2.3] (P.6)

- | | |
|---|--|
| (A) Finishing mortar (25–30 mm) | (B) Cinder concrete (70–100 mm) |
| (C) Two layers of waterproofing membrane (10–12 mm) | (D) Smoothing mortar (25–30 mm) |
| (E) Frame concrete | (F) Filled with thermal insulation materials |
| (G) Caulking (Waterproof material) | (H) Lagging (Molded paper, waterproof paper, galvanized cast iron sheet, and paint of a specified color) |
| (I) Thermal insulation material (Glass wool or rock wool) | (J) Iron pipe sleeve with collar
Determine the inner diameter of a sleeve in consideration of the outer diameter of an iron pipe, thickness of thermal insulation, and thickness of a filler. |
| (K) Cold (hot) water pipe (supply pipe) | (L) Cold (hot) water pipe (return pipe) |

- Roof penetration through mortar waterproofing membrane

[Fig. 5.2.4] (P.6)

Cross-sectional view

- | | |
|--|--|
| (A) Cold (hot) water pipe (supply and return pipe) | (B) Thermal insulation material |
| (C) Lagging (covering with galvanized steel sheet) | (D) Soldering |
| (E) Galvanized steel sheet cover | (F) Caulking (waterproof material) elastomeric sealant |
| (G) Mortar waterproofing membrane (30–100 mm) | (H) Concrete (150 mm) |

Plain view

- | | |
|--|---|
| (A) Cold (hot) water pipe (supply pipe) | (B) Cold (hot) water pipe (return pipe) |
| (C) Galvanized steel sheet cover | (D) Soldering |
| (E) Caulking (waterproof material) elastomeric sealant | (F) Mortar waterproofing membrane (30–100 mm) |
| (G) Concrete (150 mm) | |

- ④ Notes for thermal insulation work
 - (a) Complete thermal insulation work on pipes before installation of pipes and units. After the installation, thermal insulation work could not be performed.
 - (b) Leave necessary space on units for labels such as nameplates and inspection certificates issued by authorities.
 - (c) Ensure that adhesive is suitable for thermal insulation materials before applying it to the materials.
 - (d) Ensure that the exposed insulated pipes do not mar the view of the surrounding area.
 - (e) Perform thermal and cold insulation work on the inlet/outlet of pipes (to which coils are connected) of a radiator in a wall penetration.

[Fig. 5.2.5] (P.6)

Thermal and cold insulation work on a pipe penetrating through a beam

- Ⓐ Sleeve
- Ⓑ No thermal insulation
- Ⓒ Thermal insulation materials
- Ⓓ Pipe

- 2. Be sure to add insulation work to water piping by covering water pipework separately with enough thickness heat-resistant polyethylene, so that no gap is observed in the joint between indoor unit and insulating material, and insulating materials themselves. When insulation work is insufficient, there is a possibility of condensation, etc. Pay special attention to insulation work in the ceiling plenum.
- Insulation materials for the pipes to be added on site must meet the following specifications:

Branch piping for indoor unit	20 mm or more
-------------------------------	---------------

* The pipe diameter depends on the capacity of indoor units. Refer to the indoor unit installation manual for details.

- This specification is based on copper for water piping. When using plastic pipework, choose a thickness based on the plastic pipe performance.
- Thermal insulation materials should have a thickness of 20 mm or larger.
- Install a heater on site when pipes are installed outside where a temperature is 0°C or below and when the breaker may be turned off.
- After installing the heater, check that the temperatures at the inlet and outlet pipe couplings are 20°C or higher than the outside temperature (e.g., 0°C or higher at the pipe couplings when the outside temperature is -20°C).
- Select a heater of 30 W/m or greater and in consideration of adhesiveness and safety factor.
- Select a heater with an auto temperature adjustment function according to the pipe material used on the site to prevent overheating.

[Fig. 5.2.6] (P.6)

- Ⓐ Pipe
- Ⓑ Heater
- Ⓒ Adhesive tape
- Ⓓ Insulating material
- Ⓔ Covering material

- Installation of pipes in a high-temperature high-humidity environment, such as the top floor of a building, may require the use of insulation materials thicker than the ones specified in the chart above.
 - When certain specifications presented by the client must be met, ensure that they also meet the specifications on the chart above.
3. Expansion vessel

Connect an expansion vessel to the expansion vessel connection port of the hydro unit or to the return water pipe.

- Install an expansion vessel to accommodate expanded water.
- The water containment volume of the hydro unit and the indoor unit.

(Unit: L)

Unit model		Water volume
Hydro unit	CMH-WM250V-A	9.2
	CMH-WM350V-A	10.5
	CMH-WM500V-A	14.3
PEFY-W20VMA		0.7
PEFY-W25VMA		1
PEFY-W32VMA		
PEFY-W40VMA		
PEFY-W50VMA		1.8
PEFY-W63VMA		
PEFY-W71VMA		1.8
PEFY-W80VMA		1.8
PEFY-W100VMA		2.5
PEFY-W125VMA		2.5

* For other indoor units, refer to the installation manual for each.

- The maximum water temperature is 60°C.
- The minimum water temperature is 5°C.
- The circuit protection valve set pressure is 0.8-0.96 MPa.
- The circulation pump head pressure is 0.2 MPa. (CMH-WM250/350/500V-A)
- The design pressure of the expansion vessel is the charged water pressure (the reading of the pressure gauge) and pump head.

- Tank volume of expansion vessel is as follows:

$$\text{Tank volume} \geq \varepsilon \times G / (1 - X/Y) \times 1.2 \text{---(a)}$$

ε = The expansion coefficient of water
(= 0.0171)

$$X = 0.15 + A \text{---(b)}$$

$$Y = 0.15 + A + D \text{---(c)}$$

A: Vertical separation between the top of the system and the expansion vessel ([m]/100 [MPa])

B: Vertical separation between the top of the system and the lowest indoor unit ([m]/100 [MPa])

C: Vertical separation between the top of the system and the hydro unit ([m]/100 [MPa])

$$A + D + 0.25 < 0.9 \text{---(d)}$$

$$B + D + 0.25 < 0.9 \text{---(e)}$$

$$C + D + 0.25 < 0.7 \text{---(f)}$$

The design pressure of the expansion vessel is $1.1 + A - C$ [MPa] or above.

Calculate the tank volume by assigning D that satisfies (d) to (f) to formula (c).

- * Please choose ε for using antifreeze solution on the type and temperature range used.

$$\varepsilon = \text{Max density/Min density} - 1$$

$$G \text{ [L]} = (\text{Hydro unit [L]} + \text{Indoor unit [L]} + \text{Pipe [L]}) \times 1.1$$

- 4. Leakproof the water pipework, valves and drain pipework. Leakproof all the way to, and include pipe ends so that condensation cannot enter the insulated pipework.
- 5. Apply caulking around the ends of the insulation to prevent condensation getting between the pipework and insulation.
- 6. Add a drain valve so that the unit and pipework can be drained.
- 7. Ensure there are no gaps in the pipework insulation. Insulate the pipework right up to the unit.
- 8. Ensure that the gradient of the drain pan pipework is such that discharge can only blow out.
- 9. Hydro unit water pipe connection sizes and pipe sizes.

[Fig. 5.2.7] (P.6)

Indoor unit	Connection size		Pipe size	
	Water inlet	Water outlet	Water return	Water out
PEFY-W-VMA	O.D. 22.0 mm	O.D. 22.0 mm	I.D. 20 mm	I.D. 20 mm

* For other indoor units, refer to the indoor unit installation manual.

* The pipe diameter depends on the capacity of indoor units. Refer to the indoor unit installation manual for details.

- Ⓐ To outdoor unit
- Ⓑ End connection
- Ⓒ Hydro unit
- Ⓓ To main piping
- Ⓔ Indoor unit
- Ⓕ Auto air vent valve (Highest point on the water pipe) (supplied)

- 10. Please refer to the [Fig. 5.2.8] when connecting the water supply.

[Fig. 5.2.8] (P.6)

- Ⓐ Hydro unit
- Ⓑ Strainer (supplied)
- Ⓒ Water pipe
- Ⓓ Pressure gauge (not supplied)
- Ⓔ Check valve (not supplied)
- Ⓕ Shutoff valve (not supplied)
- Ⓖ Pressure reducing valve (not supplied)

- 11. Use formula $0.1 \text{ [MPa]} < 0.01 + 0.01 \times A < 0.16 \text{ [MPa]}$ for the supply pressure range to be used.
(A: Head pressure (m) between the hydro unit and the highest indoor unit)
If the supply pressure is greater than 0.16 MPa, use a pressure reducing valve to keep the pressure within the range.
If the head pressure is unknown, set it to 0.16 MPa.
- 12. Before performing a pressure test on the pipes in the water circuit, be sure to install a shutoff valve on the inlet/outlet water pipes of the indoor units. Also, install a strainer on the field-installed water pipes for easy operation and maintenance.
- 13. Apply insulation to the indoor unit pipework, strainer, shutoff valve, and pressure reducing valve.
- 14. Please do not use a corrosion inhibitor in the water system.

- 15. **When installing the hydro unit in an environment which may drop below 0°C, please add antifreeze solution (Propylene Glycol only) to the circulating water according to the local regulations. (For the relationship between antifreeze solution concentration and temperature, refer to the service handbook.)**

5.3. Water treatment and quality control

To preserve water quality, use the closed type of water circuit. When the circulating water quality is poor, the water heat exchanger can develop scale, leading to a reduction in heat-exchange power and possible corrosion. Pay careful attention to water processing and water quality control when installing the water circulation system.

- Removing of foreign objects or impurities within the pipes.
 - During installation, make sure that foreign objects, such as welding fragments, sealant particles, or rust, do not enter the pipes.
- Water Quality Processing
 - ① Depending on the quality of the cold-temperature water used in the air conditioner, the copper piping of the heat exchanger may corrode. Regular water quality processing is recommended. If a water supply tank is installed, keep air contact to a minimum, and keep the level of dissolved oxygen in the water no higher than 1mg/l.

② Water quality standard

Items		Low to mid-range temperature water system		Tendency	
		Recirculating water [20<T<60°C] [68<T<140°F]	Make-up water	Corrosive	Scale-forming
Standard items	pH (25°C) [77°F]	7.0 – 8.0	7.0 – 8.0	○	○
	Electric conductivity (mS/m) (25°C) [77°F] (μ s/cm) (25°C) [77°F]	30 or less [300 or less]	30 or less [300 or less]	○	○
	Chloride ion (mg Cl-/l)	50 or less	50 or less	○	
	Sulfate ion (mg SO4 ²⁻ /l)	50 or less	50 or less	○	
	Acid consumption (pH4.8) (mg CaCO ₃ /l)	50 or less	50 or less		○
	Total hardness (mg CaCO ₃ /l)	70 or less	70 or less		○
	Calcium hardness (mg CaCO ₃ /l)	50 or less	50 or less		○
Reference items	Ionic silica (mg SiO ₂ /l)	30 or less	30 or less		○
	Iron (mg Fe/l)	1.0 or less	0.3 or less	○	○
	Copper (mg Cu/l)	1.0 or less	0.1 or less	○	
	Sulfide ion (mg S ²⁻ /l)	not to be detected	not to be detected	○	
	Ammonium ion (mg NH ₄ ⁺ /l)	0.3 or less	0.1 or less	○	
	Residual chlorine (mg Cl/l)	0.25 or less	0.3 or less	○	
	Free carbon dioxide (mg CO ₂ /l)	0.4 or less	4.0 or less	○	
	Ryzner stability index	6.0 – 7.0	–	○	○

Reference: Guideline of Water Quality for Refrigeration and Air Conditioning Equipment. (JRA GL02E-1994)

- ③ Consult with a specialist about water quality control methods and calculations before using anti-corrosive solutions.

6. Electrical work

- ▶ Consult all related regulations and power companies beforehand.

⚠ Warning:

Electrical work should be handled by qualified electrical engineers in accordance with all related regulations and attached instruction manuals. Special circuits should also be used. If there is a lack of power capacity or a deficiency in electrical work, it may cause a risk of electric shock or fire.

- ▶ Connect all wires securely.
- Fix power source wiring to control box by using buffer bushing for tensile force (PG connection or the like).

[Fig. 6.0.1] (P.7)

CMH-WM250V-A
CMH-WM350V-A
CMH-WM500V-A

- Ⓐ Control box
- Ⓑ Power source wiring
- Ⓒ ø32 hole (closed rubber bushing)
- Ⓓ Transmission wiring
- Ⓔ Clip cables here

- ▶ Never connect the power cable to the terminal board for control cables. (Otherwise it may be broken.)
- ▶ Be sure to wire between the control wire terminal boards for indoor unit, outdoor unit and hydro unit.

Use non-polarized 2-wire as transmission cables.

Use 2-core shielding cables (CVVS, CPEVS) of more than 1.25 mm² in diameter as transmission cables.

7. Setting addresses and operating units

The address switch of each hydro unit is set to "000" when shipped from the factory.

- Set the address switch to an address that equals the address of the outdoor units that are connected to the hydro unit plus 1.
- Please refer to the outdoor unit installation manual.

8. Test run

Before commencing a test run please check the following:

- ▶ After installing, piping and wiring the indoor units and hydro units, check to see again that there is no refrigerant leakage, water leakage, the indoor unit inlet and outlet piped backwards, and no slack on power and control cables.
- ▶ Use a 500 V tester to check that there is an insulation resistance of more than 1.0 MΩ between the power terminal block and the ground. If it is less than 1.0 MΩ, do not operate the unit.
- When water has been supplied to the water pipework, purge the system of air. The details of air purging can be found separately in the water circuit maintenance manual.

The switch capacity of the main power to hydro unit and the wire size are as follows:

Switch (A)		Molded case circuit breaker	Earth leakage breaker	Wire size
Capacity	Fuse			
16	16	20 A	20 A 30 mA 0.1 s or less	1.5 mm ²

- For other detailed information, refer to the outdoor unit installation manual.
- Power supply cords of appliances shall not be lighter than design 245 IEC 53 or 227 IEC 53.
- A switch with at least 3 mm contact separation in each pole shall be provided by the Air conditioner installation.
- When air flow decrease is detected of a circulation fan beside the hydro unit installed at the height of less than 1.8 m from the ground, the system must be powered off within 10 seconds from the detection. Before powering off the system, connect the contactor to the power cable of the outdoor unit and open the contactor. For the connection procedures, specifications, and installation location of the contactor, refer to the manual of the outdoor unit.

⚠ Caution:

Do not use anything other than the correct capacity fuse and breaker. Using fuse, conductor or copper wire with too large capacity may cause a risk of malfunction or fire.

Ensure that the outdoor units are put to the ground. Do not connect the earth cable to any gas pipe, water pipe, lightning rod or telephone earth cable. Incomplete grounding may cause a risk of electric shock.

⚠ Caution:

- Never measure the insulation resistance of the terminal block for any control cables.
- Incomplete purging of the air in the system, closing of the valves upstream or down stream of the pump etc. may cause the pump to operate with no water flow and thus lead to pump failure.
- Ensure that the power is off when replacing a pump. Do not remove or attach the pump connector with the power on. Otherwise pump will break. After turning off the power, wait 10 minutes before commencing work.





HYDRO UNIT

<u>MODEL</u>	<u><H></u>
<u>REFRIGERANT</u>	<u>R32</u>
<u>ALLOWABLE PRESSURE(Ps)</u>	<u>4.15MPa(41.5bar)</u>
<u>MAXIMUM WATER PRESSURE</u>	<u>0.8MPa(8.0bar)</u>
<u>WEIGHT</u>	<u>kg</u>
<u>IP CODE</u>	<u>IP24</u>
<u>YEAR OF MANUFACTURE</u>	_____

SERIAL No.

UNIT RATING ~	V	220	230	240
FREQUENCY Hz		50/60	50/60	50/60
RATED INPUT (Cooling)kW				
RATED CURRENT(Cooling) A				
RATED INPUT (Heating)kW				
RATED CURRENT(Heating) A				

MANUFACTURER:
 MITSUBISHI ELECTRIC CORPORATION
 AIR-CONDITIONING & REFRIGERATION SYSTEMS WORKS
 5-66, TEBIRA, 6-CHOME, WAKAYAMA CITY, JAPAN
 MADE IN JAPAN

DWG.No.KL79T597

This product is designed and intended for use in the residential,
commercial and light-industrial environment.

The product at hand is
based on the following
EU regulations:

- Low Voltage Directive 2014/35/EU
- Electromagnetic Compatibility Directive
2014/30/EU
- Machinery Directive 2006/42/EC

Please be sure to put the contact address/telephone number on
this manual before handing it to the customer.

mitsubishi **ELECTRIC CORPORATION**

HEAD OFFICE: TOKYO BLDG., 2-7-3, MARUNOUCHI, CHIYODA-KU, TOKYO 100-8310, JAPAN