

Model name:

# **BMS-IFMB0AWR-E**

## **MB Interface**

**Modbus RTU (RS-485) Interface**  
**for Toshiba AIR TO WATER HEAT PUMP**

**User Manual**  
**Issue Date: 29/09/2017**

© TOSHIBA CARRIER EUROPE S.A.S 2017 ALL Rights Reserved.

Information in this document is subject to change without notice. No part of this publication may be reproduced, stored in a retrieval system or transmitted in any form or any means electronic or mechanical, including photocopying and recording for any purpose other than the purchaser's personal use without the written permission of TOSHIBA CARRIER EUROPE S.A.S

**TRADEMARKS**

All trademarks and tradenames used in this document are acknowledged to be the copyright of their respective holders.

---

1. Presentation .....	4
2. Connection .....	5
2.1 Connect to the Hydro unit .....	5
2.2 Connection to the RS-485 bus .....	5
3. Modbus Interface Specification .....	6
3.1 Modbus physical layer .....	6
3.2 Modbus Registers for Standard Functions .....	6
3.2.1 Hydro Unit Control and Status Registers .....	6
3.2.2 Hydro Unit Setting Status .....	7
3.2.3 Configuration Registers .....	8
3.3 DIP-switch Configuration Interface .....	8
3.4 Implemented Functions .....	10
3.5 Device LED indicator .....	10
3.6 RS-485 bus. Termination resistors and Fail Safe Biasing mechanism .....	10
4. Specifications .....	11
5. Supported ESTIA Unit Types .....	11
6. Check Code .....	12

# 1. Presentation

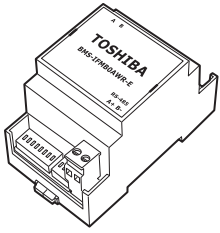

The BMS-IFMB0AWR-E interface allows a complete and natural integration of Toshiba air conditioners into Modbus RTU (RS-485) networks.

The BMS-IFMB0AWR-E is compatible with the Toshiba ESTIA AW-LINK lines.

- Reduced dimensions. 90(93) x 53 x 58 mm.
- Quick and easy installation.  
*Mountable on DIN rail, wall*
- External power not required.
- Direct connection to Modbus RTU (RS-485) networks.  
*BMS-IFMB0AWR-E is a Modbus slave device.*
- Direct connection to the Hydro unit.
- Configuration from both on-board DIP-switches and Modbus RTU.
- Total Control and Supervision.
- Real states of the Hydro unit's internal variables.
- Allows using simultaneously the Remote Controller and Modbus RTU.

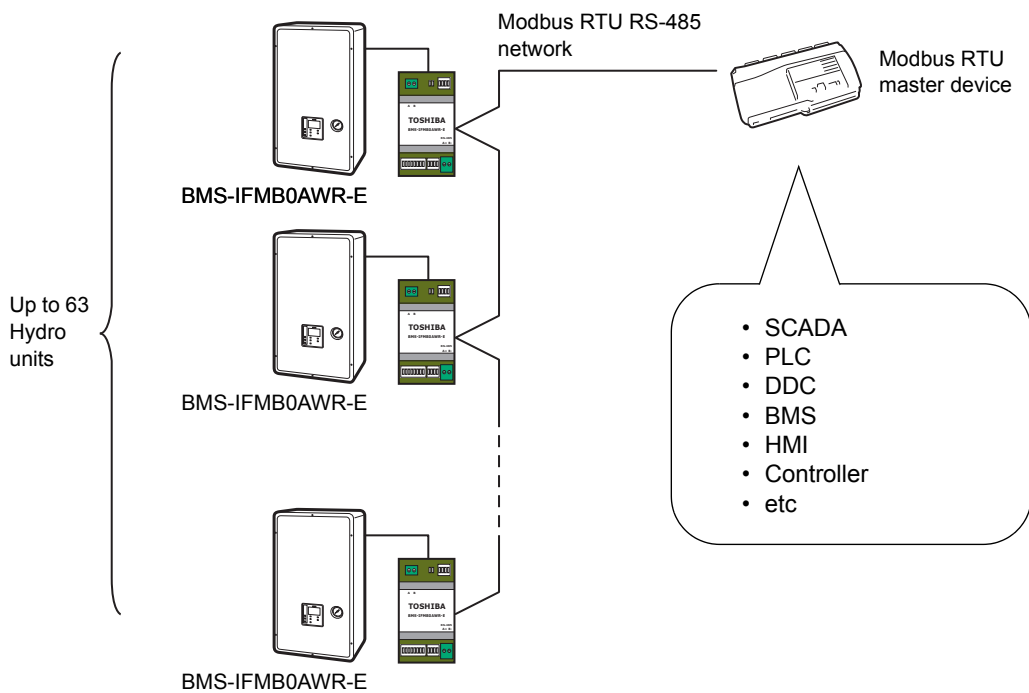

## 2. Connection

The interface comes with two plug-in terminal blocks of 2 poles for connection to a Modbus RTU RS-485 network and to the Toshiba ESTIA AW-LINK(AW-LINK).

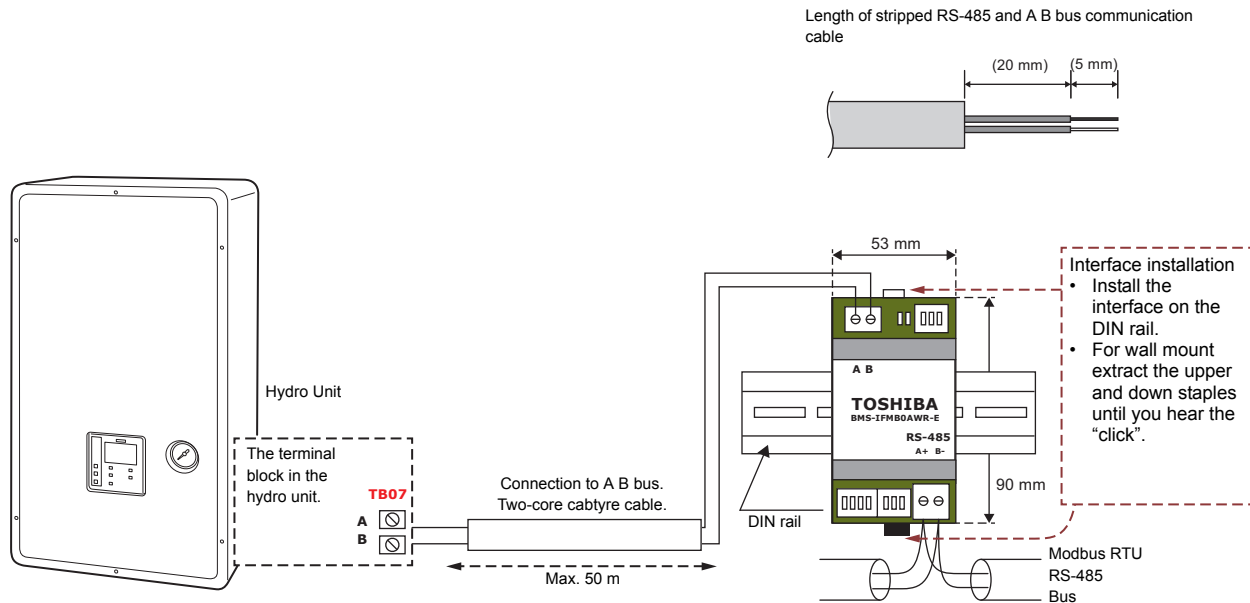

### 2.1 Connect to the Hydro unit

To connect the BMS-IFMB0AWR-E interface to the Hydro unit follow these steps:

Disconnect mains power from the Hydro unit. Open the front cover of the Hydro unit in order to have access to the electronic circuit. In the electronic circuit locate the socket connector marked as AB<sup>1</sup>.

Using a cable connect the interface to AW-LINK in any point of the bus. The AW-LINK is the bus that connects the Hydro unit and the wired remote controller, is a two-wire bus connecting terminals AB of both and has no specific polarity. Respect the maximum distance of 50 m for the bus length.

#### Caution

When using the BMS-IFMB0AWR-E, only one remote controller (Header) is connected to the AB bus. The sub-remote controller cannot be connected.

### 2.2 Connection to the RS-485 bus

Connect the RS-485 bus wires to the plug-in terminal block (the one of two poles) of BMS-IFMB0AWR-E, respect the polarity on this connection (A+ and B-). Respect the maximum distance of 500 meters for the bus, no loop or star topologies are allowed for RS-485 bus, a terminator resistor of 120  $\Omega$  must be present at each end of the bus to avoid signal reflections and also a fail-safe biasing mechanism (see section 3.7 for more details).

1. In some models, the AB connector is not present. Find the Remote Controller bus and connect the cable coming from the gateway into these cables as if they were the AB connector.

## 3. Modbus Interface Specification

### 3.1 Modbus physical layer

BMS-IFMB0AWR-E implements a Modbus RTU (slave) interface, to be connected to an RS-485 line. It performs 8N2 (8N1-compatible) communication (8 data bits, no parity and 2 stop bit) with several available baud rates (2400 bps, 4800bps, 9600 bps -default-, 19200 bps).

The relationship between the start address specified in a request from the master device and the value shown by “Modbus-address for registers” in the address assignment table is as follows:

For Holding Register

Start address = (Value of Modbus-address for registers) – 40001

### 3.2 Modbus Registers for Standard Functions

All registers are of type “16-bit signed Holding Register”, in standard Modbus’ big endian notation.

#### 3.2.1 Hydro Unit Control and Status Registers

Modbus Register	R/W	Item		5 Series	4 Series
40001	R/W	Zone1/2 ON/OFF setting/monitor	0 : OFF 1 : ON	✓	✓
40002	R/W	HOT WATER On/Off	0 : OFF 1 : ON	✓	✓
40003	R/W	Zone1 / Zone 2 Operation Mode setting / Monitor	1:Heat 2:Cool *3	✓	✓
40004	R/W	Zone1 Temperature Setting °C	°C *1, *2	✓	✓
40005	R/W	Zone2 Temperature Setting °C	°C *1, *2	✓	✓
40006	R/W	HOT WATER Temperature Setting °C	°C *1, *2	✓	✓
40007	R/W	AUTO TEMP operation On/Off	0 : OFF 1 : ON	✓	✓
40008	R/W	Night setback operation On/Off	0 : OFF 1 : ON	✓	✓
40009	R/W	HOT WATER boost On/Off	0 : OFF 1 : ON	✓	✓
40010	R/W	Frost protection operation On/Off	0 : OFF 1 : ON	✓	✓
40011	R/W	ANTI BACTERIA operation On/Off	0 : OFF 1 : ON	✓	✓
40012	R	Alarm Status	0:No alarm condition 1:Alarm condition	✓	✓
40013	R	Alarm Code	0 - 255 (Refer to Section 6) -1: communication error -3: paused -4: initialization	✓	✓
40014	R	Alarm Unit	0x00 Interface 0x60 Remote controller 0x7x Hydro Unit (x : 0-7)	✓	✓
40015	R	Zone1 Control Temperature °C	°C *1, *2	✓	✓
40016	R	Zone2 Control Temperature °C	°C *1, *2	✓	✓
40017	R	HOT WATER control Temperature °C	°C *1, *2	✓	✓
40018	R	Control Temperature	Control Temperature for ESTIA °C *1, *2	✓	-
40019	R	Outside Temperature	TO sensor °C *1, *2	✓	✓
40020	R	DHW cylinder water temperature	TTW sensor °C *1, *2	✓	✓
40022	R	Water inlet temperature	TWI sensor °C *1, *2	✓	✓
40023	R	Water outlet temperature	TWO sensor °C *1, *2	✓	✓

Modbus Register	R/W	Item		5 Series	4 Series
40024	R	Water heater outlet temperature	THO sensor °C *1, *2	✓	✓
40025	R	Floor heating circuit inlet temperature	TFI sensor °C *1, *2	✓	✓
40035	R	DHW mode compressor ON Integrated time (x1hrs)		✓	✓
40036	R	Heating mode compressor ON Integrated time (x1hrs)		✓	✓
40037	R	Cooling mode compressor ON Integrated time (x1hrs)		✓	✓
40038	R	Hydro unit water pump operation Integrated time (x1hrs)		✓	✓
40039	R	DHW cylinder heater ON Integrated time (x1hrs)		✓	✓
40040	R	Hydro unit Back Up Heater ON Integrated time (x1hrs)		✓	✓

(\*1) Temperature data °C x1 (S4 Bit1 OFF) / x10°(S4 Bit1 ON)

(\*2) Temperature Read data 0x8000 means No Sensor or Sensor Error.

(\*3) If Cool mode prohibit, never set Cool mode.

### 3.2.2 Hydro Unit Setting Status

Addr	R/W	Item		5 Series	4 Series
40201	R	Zone1 Device Connection Status	0-No Connection , 1-Connect	✓	✓
40202	R	Zone2 Device Connection Status	0-No Connection , 1-Connect	✓	✓
40203	R	HOT WATER Device Connection Status	0-No Connection , 1-Connect	✓	✓
40204	R	Zone1 and 2 Cooling Upper limit Setting Temperature (MAX) °C	°C *1	✓	✓
40205	R	Zone1 and 2 Cooling Lower limit Setting Temperature (MIN) °C	°C *1	✓	✓
40206	R	Zone 1 Heating Mode, Upper limit Water Temperature (MAX) °C	°C *1	✓	✓
40207	R	Zone 1 Heating Mode, Lower limit Water Temperature (MIN) °C	°C *1	✓	✓
40208	R	Zone 2 Heating Mode, Upper limit Water Temperature (MAX) °C	°C *1	✓	✓
40209	R	Zone 2 Heating Mode, Lower limit Water Temperature (MIN) °C	°C *1	✓	✓
40210	R	Hot Water Mode, Upper limit Water Temperature (MAX) °C	°C *1	✓	✓
40211	R	Hot Water Mode, Lower limit Water Temperature (MIN) °C	°C *1	✓	✓
40212	R	Frost Protection Setting Temperature °C	°C *1	✓	✓
40213	R	HOT WATER boost Setting Temperature °C	°C *1	✓	✓
40214	R	ANTIBACTERIA Setting Temperature °C	°C *1	✓	✓
40215	R	Operation Mode Permit/Prohibit	0-ALL mode prohibit, 1-Cooling only, 2-Heating only, 3-Heating and cooling	✓	✓
40216	R	Auto Temp Setting Function Setting	0:unused 1:use	✓	✓
40217	R	Frost Protection Function Setting Status	0:unused 1:use	✓	✓
40219	R	Night Set Back Function Setting Status	0:unused 1:use	✓	✓
40220	R	Hot Water Boost Function Status	0:unused 1:use	✓	✓

Addr	R/W	Item		5 Series	4 Series
40221	R	AntiBacteria Function Status	0:unused 1:use	✓	✓

(\*1) Temperature data °C x1 (S4 Bit1 OFF) / x10°(S4 Bit1 ON)

### 3.2.3 Configuration Registers

Addr	R/W	Item		5 Series	4 Series
40041	R	Modbus baud rate	0:2400bps 1:4800bps 2:9600bps 3:19200bps	✓	✓
40042	R	Modbus Slave Address	1 to 63	✓	✓
40050	R	Device Definition	0x2C00	✓	✓
40051	R	Software Version		✓	✓
40052	R	Hydro Unit Type	4 : 4Series 5 : 5 Series	✓	✓

#### Precaution

When the temperature setting is made for Zones 1/2 from the BMS-IFMB0AWR-E, the actual water temperature may be lower than the set temperature depending on the FC setting of the remote controller.

## 3.3 DIP-switch Configuration Interface

All configuration values on BMS-IFMB0AWR-E can be written and read from Modbus interface. Though, some of them can also be setup from its on-board DIP-switch interface.

They are DIP-switches S1\*, S3\* and S4 on the device, in the following location:

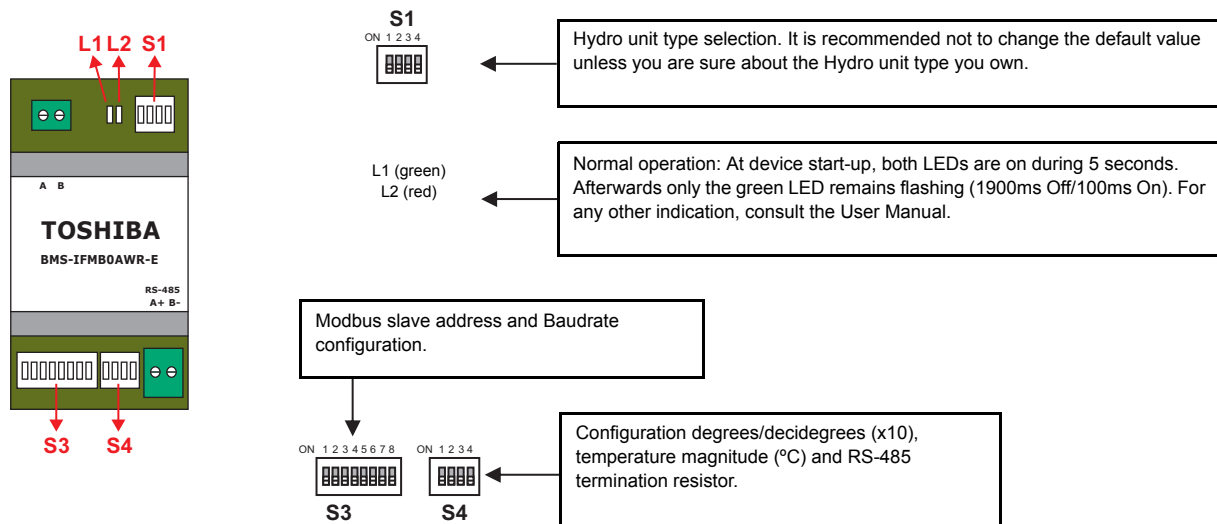

The following table applies for configuration of the interface through these DIP-switches:

#### S1 - Hydro unit type

Switches 1 2 3 4	Description
↓ ↓ x x	Estia Hydro unit 5 series, (default)
↑ ↓ x x	Estia Hydro unit 4 series
↓ ↑ x x	Reserve.
↑ ↑ x x	Reserve.

Table 3.1 Hydro Unit Type



**S3 - Modbus protocol: Slave address and baudrate**

Switches 1 2 3 4 5 6 7 8	Description
x x x x x ↓ ↓	2400bps
x x x x x ↑ ↓	4800bps
x x x x x ↓ ↑	9600bps (- default value)
x x x x x ↑ ↑	19200bps

**Table 3.2 Modbus baud rate**

Add	Switches 1 2 3 4 5 6 7 8	Add	Switches 1 2 3 4 5 6 7 8	Add	Switches 1 2 3 4 5 6 7 8	Add	Switches 1 2 3 4 5 6 7 8
0	↓ ↓ ↓ ↓ ↓ ↓ x x	16	↓ ↓ ↓ ↓ ↑ ↓ x x	32	↓ ↓ ↓ ↓ ↓ ↑ x x	48	↓ ↓ ↓ ↓ ↑ ↑ x x
1*	↑ ↓ ↓ ↓ ↓ ↓ x x	17	↑ ↓ ↓ ↓ ↑ ↓ x x	33	↑ ↓ ↓ ↓ ↓ ↑ x x	49	↑ ↓ ↓ ↓ ↑ ↑ x x
2	↓ ↑ ↓ ↓ ↓ ↓ x x	18	↓ ↑ ↓ ↓ ↑ ↓ x x	34	↓ ↑ ↓ ↓ ↓ ↑ x x	50	↓ ↑ ↓ ↓ ↑ ↑ x x
3	↑ ↑ ↓ ↓ ↓ ↓ x x	19	↑ ↑ ↓ ↓ ↑ ↓ x x	35	↑ ↑ ↓ ↓ ↓ ↑ x x	51	↑ ↑ ↓ ↓ ↑ ↑ x x
4	↓ ↓ ↑ ↓ ↓ ↓ x x	20	↓ ↓ ↑ ↓ ↑ ↓ x x	36	↓ ↓ ↑ ↓ ↓ ↑ x x	52	↓ ↓ ↑ ↓ ↑ ↑ x x
5	↑ ↓ ↑ ↓ ↓ ↓ x x	21	↑ ↓ ↑ ↓ ↑ ↓ x x	37	↑ ↓ ↑ ↓ ↓ ↑ x x	53	↑ ↓ ↑ ↓ ↑ ↑ x x
6	↓ ↑ ↑ ↓ ↓ ↓ x x	22	↓ ↑ ↑ ↓ ↑ ↓ x x	38	↓ ↑ ↑ ↓ ↓ ↑ x x	54	↓ ↑ ↑ ↓ ↑ ↑ x x
7	↑ ↑ ↑ ↓ ↓ ↓ x x	23	↑ ↑ ↑ ↓ ↑ ↓ x x	39	↑ ↑ ↑ ↓ ↓ ↑ x x	55	↑ ↑ ↑ ↓ ↑ ↑ x x
8	↓ ↓ ↓ ↑ ↓ ↓ x x	24	↓ ↓ ↓ ↑ ↑ ↓ x x	40	↓ ↓ ↓ ↑ ↓ ↑ x x	56	↓ ↓ ↓ ↑ ↑ ↑ x x
9	↑ ↓ ↓ ↑ ↓ ↓ x x	25	↑ ↓ ↓ ↑ ↑ ↓ x x	41	↑ ↓ ↓ ↑ ↓ ↑ x x	57	↑ ↓ ↓ ↑ ↑ ↑ x x
10	↓ ↑ ↓ ↑ ↓ ↓ x x	26	↓ ↑ ↓ ↑ ↑ ↓ x x	42	↓ ↑ ↓ ↑ ↓ ↑ x x	58	↓ ↑ ↓ ↑ ↑ ↑ x x
11	↑ ↑ ↓ ↑ ↓ ↓ x x	27	↑ ↑ ↓ ↑ ↑ ↓ x x	43	↑ ↑ ↓ ↑ ↓ ↑ x x	59	↑ ↑ ↓ ↑ ↑ ↑ x x
12	↓ ↓ ↑ ↑ ↓ ↓ x x	28	↓ ↓ ↑ ↑ ↑ ↓ x x	44	↓ ↓ ↑ ↑ ↓ ↑ x x	60	↓ ↓ ↑ ↑ ↑ ↑ x x
13	↑ ↓ ↑ ↑ ↓ ↓ x x	29	↑ ↓ ↑ ↑ ↑ ↓ x x	45	↑ ↓ ↑ ↑ ↓ ↑ x x	61	↑ ↓ ↑ ↑ ↑ ↑ x x
14	↓ ↑ ↑ ↑ ↓ ↓ x x	30	↓ ↑ ↑ ↑ ↑ ↓ x x	46	↓ ↑ ↑ ↑ ↓ ↑ x x	62	↓ ↑ ↑ ↑ ↑ ↑ x x
15	↑ ↑ ↑ ↑ ↓ ↓ x x	31	↑ ↑ ↑ ↑ ↑ ↓ x x	47	↑ ↑ ↑ ↑ ↓ ↑ x x	63	↑ ↑ ↑ ↑ ↑ ↑ x x

\* Default value

**Table 3.3 Modbus Slave address****S4 - Other: Degrees/Decidegree (x10), temperature magnitude (°C/°F) and RS-485 termination resistor**

Switches 1 2 3 4	Description
↓ x x x	Temperature values in Modbus register are represented in degrees (x1) (default value)
↑ x x x	Temperature values in Modbus register are represented in decidegrees (x10)
x ↓ x x	Temperature values in Modbus register are represented in Celsius degrees (default value)
x ↑ x x	Temperature values in Modbus register are represented in Fahrenheit degrees
x x x ↓	RS-485 bus without termination resistor (default value)
x x x ↑	Internal termination resistor of 120Ω connected to RS-485 bus*

\* Only in the interfaces connected at both ends of the bus must be activated the termination resistor. More information in section 3.6

**Table 3.4 Temperature and termination configuration**

## 3.4 Implemented Functions

BMS-IFMB0AWR-E implements the following standard Modbus functions:

- 3: Read Holding Registers
- 6: Write Single Register
- 16: Write Multiple Registers (Although this function is allowed, the interface does not allow write operations on more than 1 register with the same request, this means that length field should always be 1 when using this function for writes)

## 3.5 Device LED indicator

The device includes two LED indicators to signal its different possible operational states. In this section their meaning is explained

L1 (yellow)			
Operation	ON	OFF	Meaning
Blinking	500 ms	500 ms	Communication error
Flashing	100 ms	1900 ms	Normal operation (configured and working)
L1 (green) & L2 (red)			
Operation	ON	OFF	Meaning
Pulse	5 sec	--	Device start-up
Alternate blinking	500 ms	500 ms	EEPROM failure

## 3.6 RS-485 bus. Termination resistors and Fail Safe Biasing mechanism

RS-485 bus requires a 120Ω terminator resistor at each end of the bus to avoid signal reflections.

In order to prevent fail status detections by the receivers "listening" the bus when all the transmitters outputs are in three-state (high impedance), it is also required a fail-safe biasing mechanism. This mechanism provides a safe status (a correct voltage level) in the bus when all the transmitters' outputs are in three-state.

The BMS-IFMB0AWR-E device includes an on-board terminator resistor of 120Ω that can be connected to the RS-485 bus by using DIP-switch S4 Bit4, ON : 120Ω, OFF : without terminal register.

Fail safe biasing of the RS-485 bus must only be supplied by one of the devices connected to the bus. The device providing fail safe biasing or terminator resistor should be the one connected at one end of the bus. At the other end of the bus, if there is also a BMS-IFMB0AWR-E device, select the 120Ω terminator resistor through DIP-switch P5, or if there is a master device not providing internal 120Ω terminator resistor, connect an external 120Ω resistor in the bus terminal block connection of such master device.

*Some Modbus RTU RS-485 master devices can provide also internal 120Ω terminator resistor and/or fail safe biasing (consult the technical documentation of the master device connected to the RS-485 network in every case).*

## 4. Specifications

<b>Dimensions:</b>	90(93) x 53 x 58 mm
<b>Weight:</b>	85 g
<b>Operating Temperature:</b>	0 . . . 40°C
<b>Stock Temperature:</b>	0 . . . 40°C
<b>Operating Humidity:</b>	<95% RH, non-condensing
<b>Stock Humidity:</b>	<95% RH, non-condensing
<b>Isolation voltage:</b>	1500 VDC
<b>Isolation resistance:</b>	1000 MΩ
<b>Modbus Media:</b>	Compatible with Modbus RTU – RS-485 networks

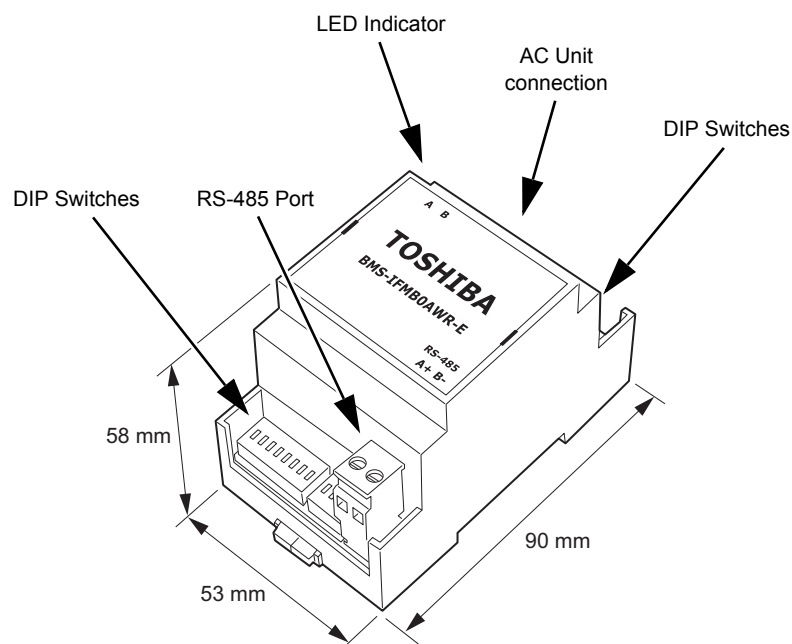

## 5. Supported ESTIA Unit Types

The BMS-IFMB0AWR-E supports the 4-Series and 5-Series ESTIA Hydro Units.

## 6. Check Code

Check code		Alarm Unit	Alarm Description
Hexadecimal Number	Remote Controller Display		
00	N/A	I/F	
01	A01	Hydro Unit	Pump or flowing quantity error
02	A02	Hydro Unit	Temperature increase error (Heating)
03	A03	Hydro Unit	Temperature increase error (Hot Water Supply)
04	A04	Hydro Unit	Antifreeze operation (1)
05	A05	Hydro Unit	Piping antifreeze operation
07	A07	Hydro Unit	Pressure switch operation
08	A08	Hydro Unit	Low pressure sensor operation error
09	A09	Hydro Unit	Overheat protection operation
0A	A10	Hydro Unit	Antifreeze operation (2)
0B	A11	Hydro Unit	Operation of the release protection
0C	A12	Hydro Unit	Heating, hot water heater
0D	A13	Hydro Unit	Pump error
41	E01	Remote Controller	No communication between hydro unit and remote controller
42	E02	Remote Controller	Defect in the signal transmission to the hydro unit.
43	E03	Hydro Unit	Regular communication error between hydro unit and remote controller
44	E04	Hydro Unit	Regular communication error between hydro unit and outdoor unit
48	E08	Hydro Unit	Duplicate address of Hydro unit, or Duplicate master Hydro unit during Group control
49	E09	Remote Controller	Several remote controller base units
52	E18	Hydro Unit	Regular communication error between master Hydro unit and slave Hydro unit during Group control
63	F03	Hydro Unit	TC sensor error
64	F04	Outdoor Unit	TD sensor error
66	F06	Outdoor Unit	TE sensor error
67	F07	Outdoor Unit	TL sensor error
68	F08	Outdoor Unit	TO sensor error
6A	F10	Hydro Unit	TWI sensor error
6B	F11	Hydro Unit	TWO sensor error
6C	F12	Outdoor Unit	TS sensor error
6D	F13	Outdoor Unit	TH sensor error
6E	F14	Hydro Unit	TTW sensor error
6F	F15	Outdoor Unit	TE, TS sensors error
71	F17	Hydro Unit	TFI sensor error
72	F18	Hydro Unit	THO sensor error
73	F19	Hydro Unit	Detection of THO disconnection error
74	F20	Hydro Unit	TFI sensor error
77	F23	Hydro Unit	Low pressure sensor error
7D	F29	Hydro Unit	EEROM error

Check code		Alarm Unit	Alarm Description
Hexadecimal Number	Remote Controller Display		
7E	F30	Hydro Unit	Extended IC error
7F	F31	Outdoor Unit	EEPROM error
81	H01	Outdoor Unit	Compressor
82	H02	Outdoor Unit	Compressor lock
83	H03	Outdoor Unit	Defect in the current detection circuit
84	H04	Outdoor Unit	Operation of case thermostat
C2	L02	Hydro Unit	Combination
C7	L07	Hydro Unit	Communication error
C9	L09	Hydro Unit	Communication error
CA	L10	Outdoor Unit	Unset service PC board jumper
CF	L15	Outdoor Unit	Combination error
D0	L16	Hydro Unit	Setting error
DD	L29	Outdoor Unit	The communication between the outdoor PC board MUCs error
E3	P03	Outdoor Unit	The outlet temperature error
E4	P04	Outdoor Unit	The high pressure switch error
E5	P05	Outdoor Unit	The power supply voltage error
E7	P07	Outdoor Unit	Overheating of heat-sink error
EF	P15	Outdoor Unit	Detection of gas leak
F3	P19	Outdoor Unit	The 4-way valve inversion error
F4	P20	Outdoor Unit	High pressure protection operation
F6	P22	Outdoor Unit	Outdoor fan system
FA	P26	Outdoor Unit	Short circuit of the compressor driver element error
FD	P29	Outdoor Unit	Compressor rotor position error
FF	P31	Hydro Unit	Slave Hydro unit error which occurs when error occurs in master Hydro unit
FFFF(-1)	-	I/F	Error in the communication of BMS-IFMB0AWR-E device with the Hydro unit

In case you detect an error code not listed, contact your nearest Toshiba technical support service.

**TOSHIBA CARRIER EUROPE S.A.S**

Route de Thil 01120 Montluel France